

i

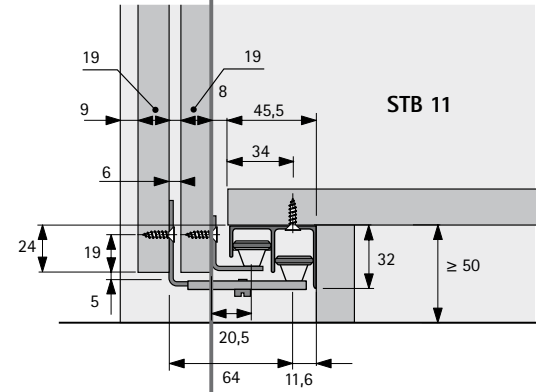

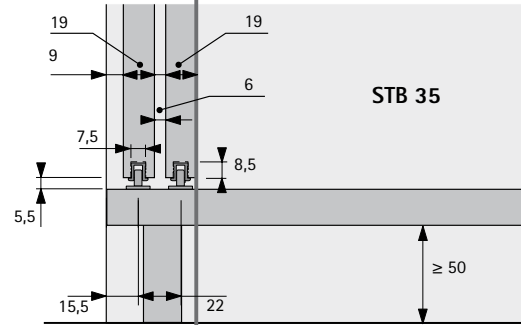

2a

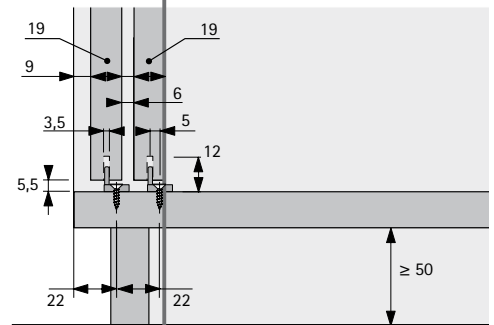
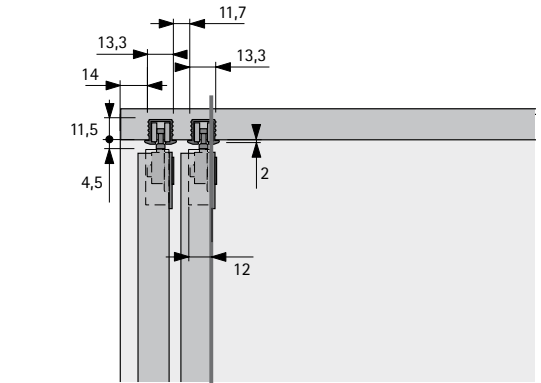
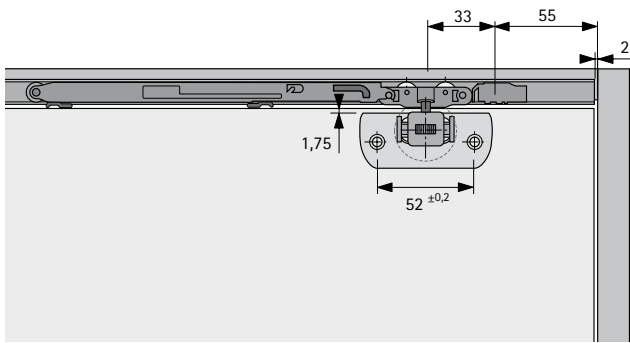
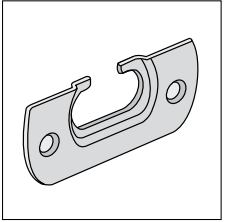
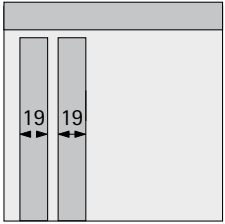
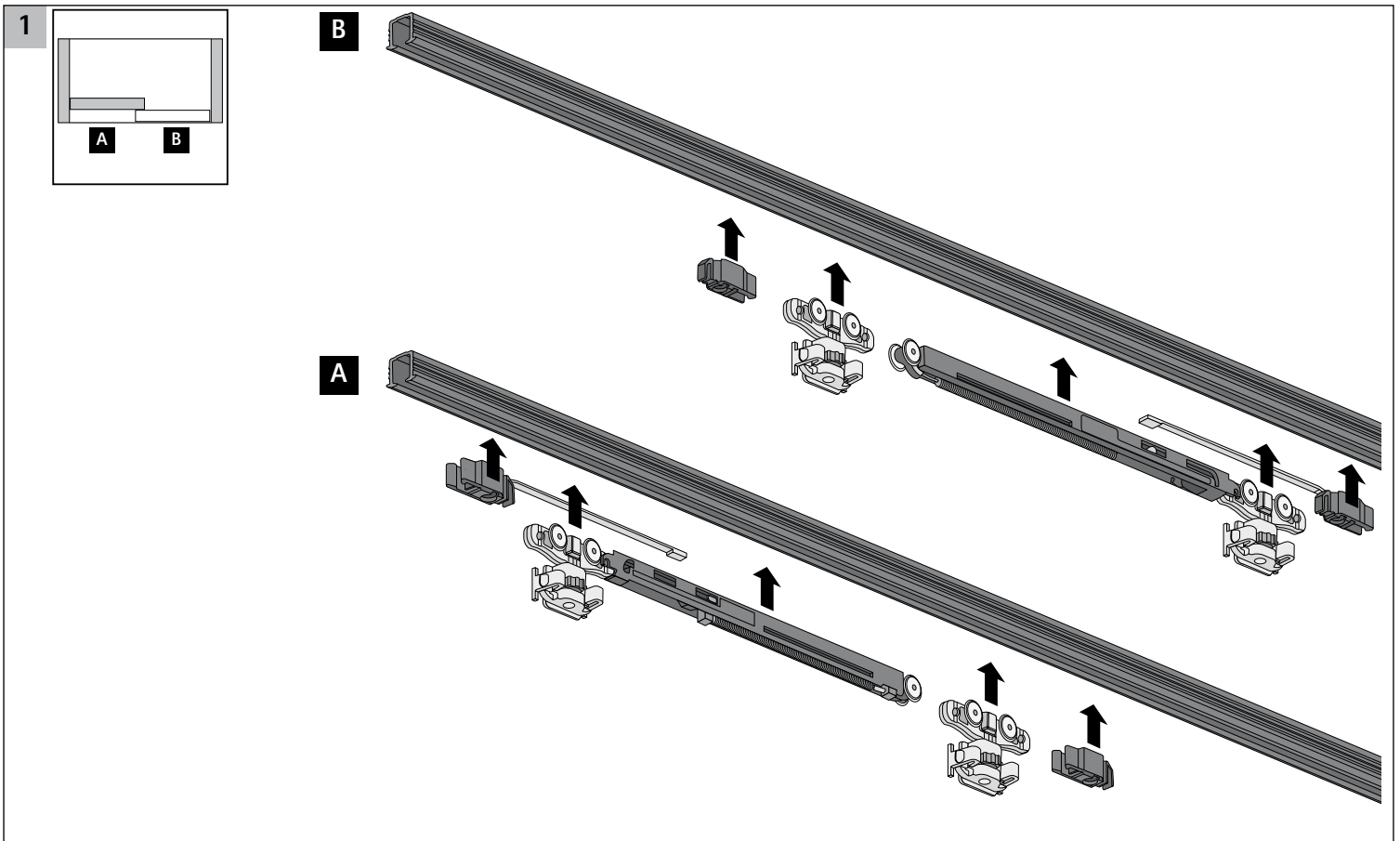
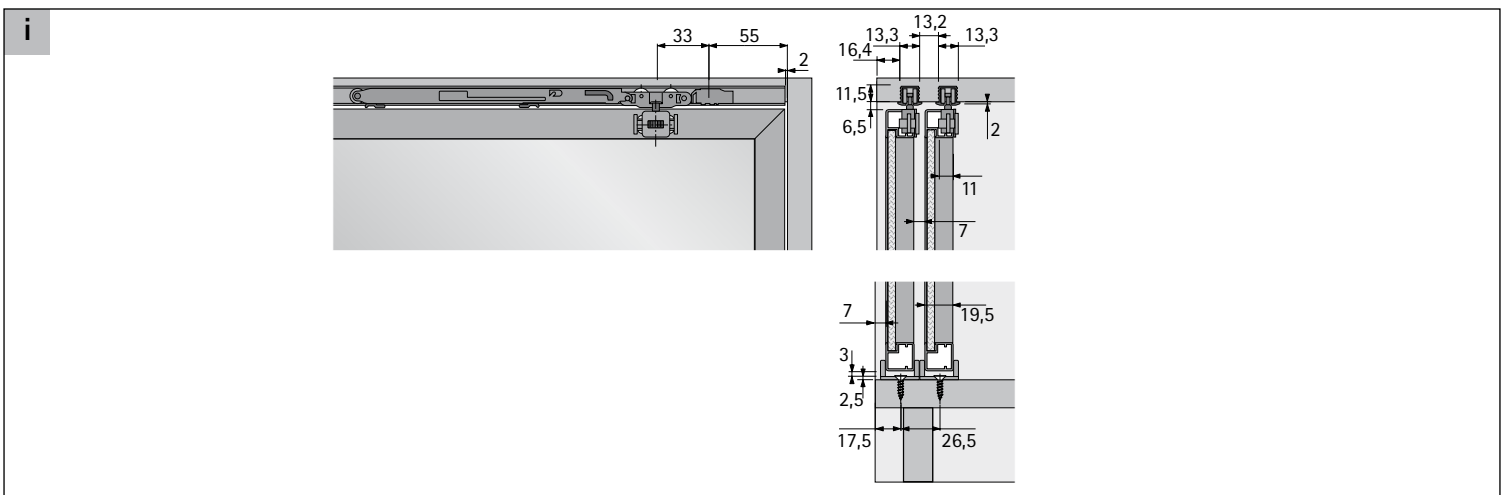
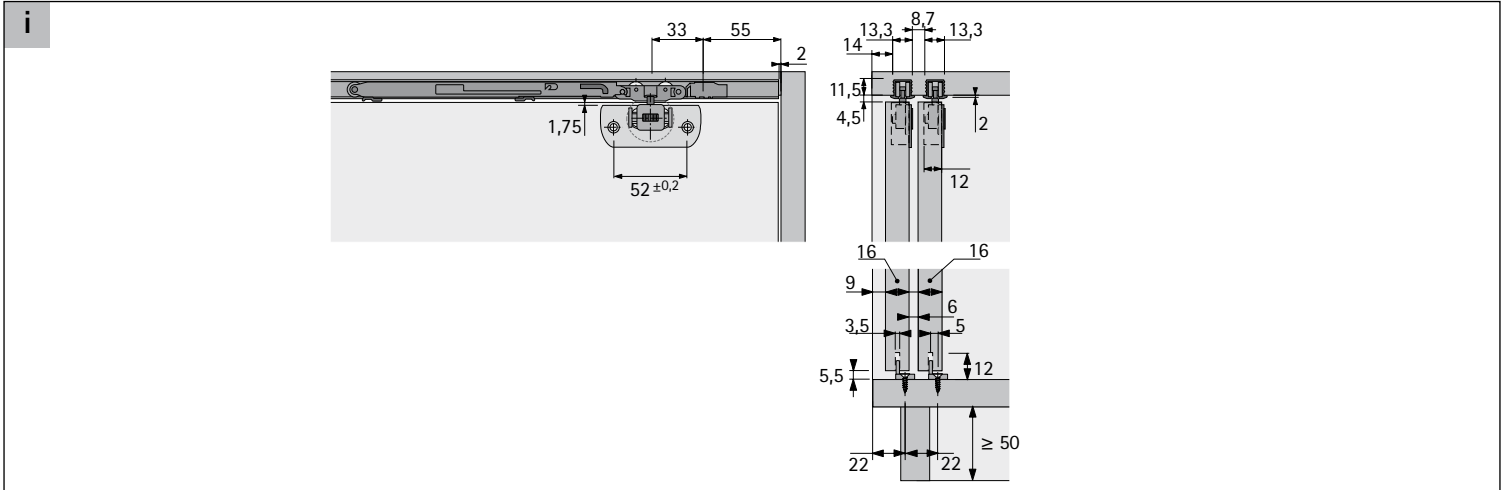
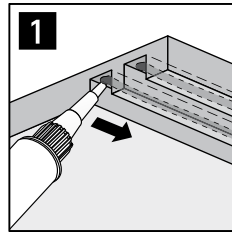
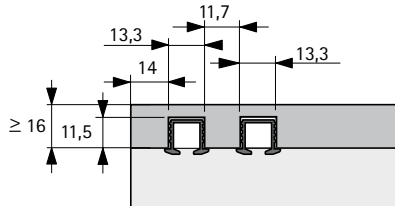
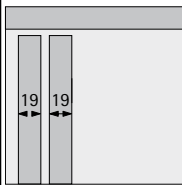
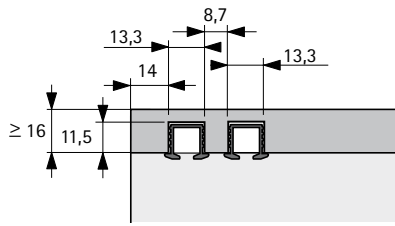
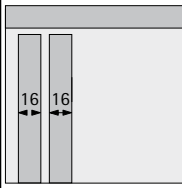

Wir empfehlen:  
Jowapur 685.32 oder  
Jowapur 685.52

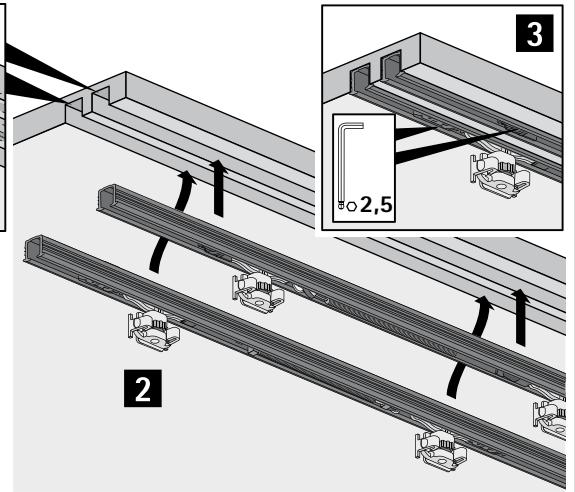

2b\*

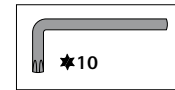
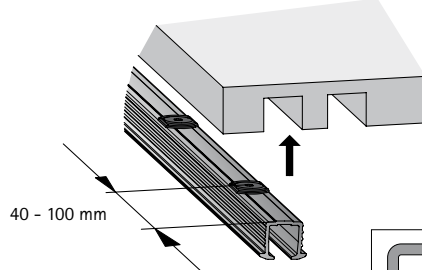
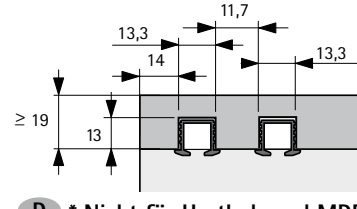
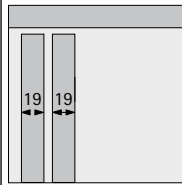
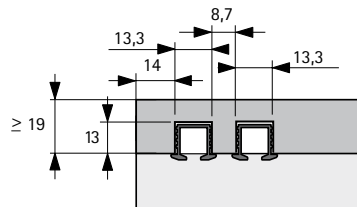
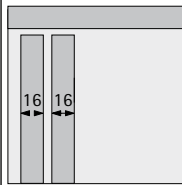

- D** \* Nicht für Hartholz und MDF verwendbar.
- GB** \* "Cannot be used for hardwood and MDF.
- F** \* Ne convient pas pour bois durs et MDF.
- I** \* Non utilizzare su legno massiccio e MDF.

- ES** \* No aplicable en madera maciza ni en MDF.
- NL** \* Niet geschikt voor hard hout en MDF.
- PL** \* Nie nale y u w przypadku twardego drewna i MDF.
- CS** \* Nelze použit pro tvrdé dřevo a MDF.

2c

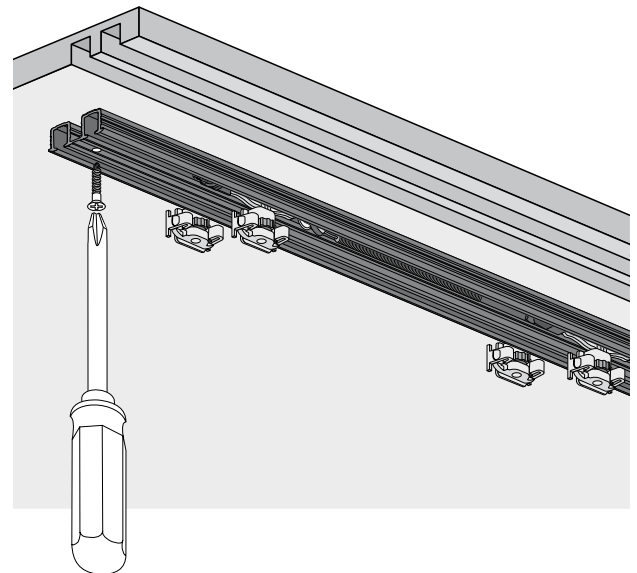
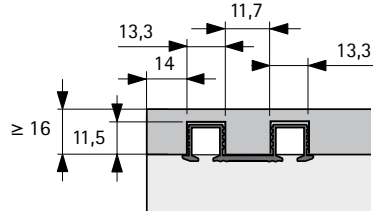
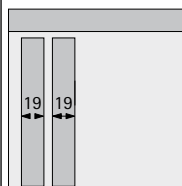
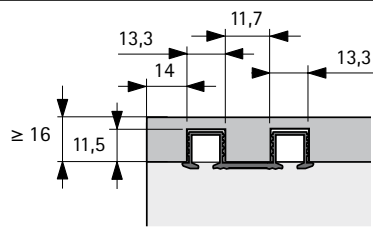
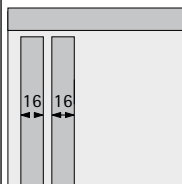

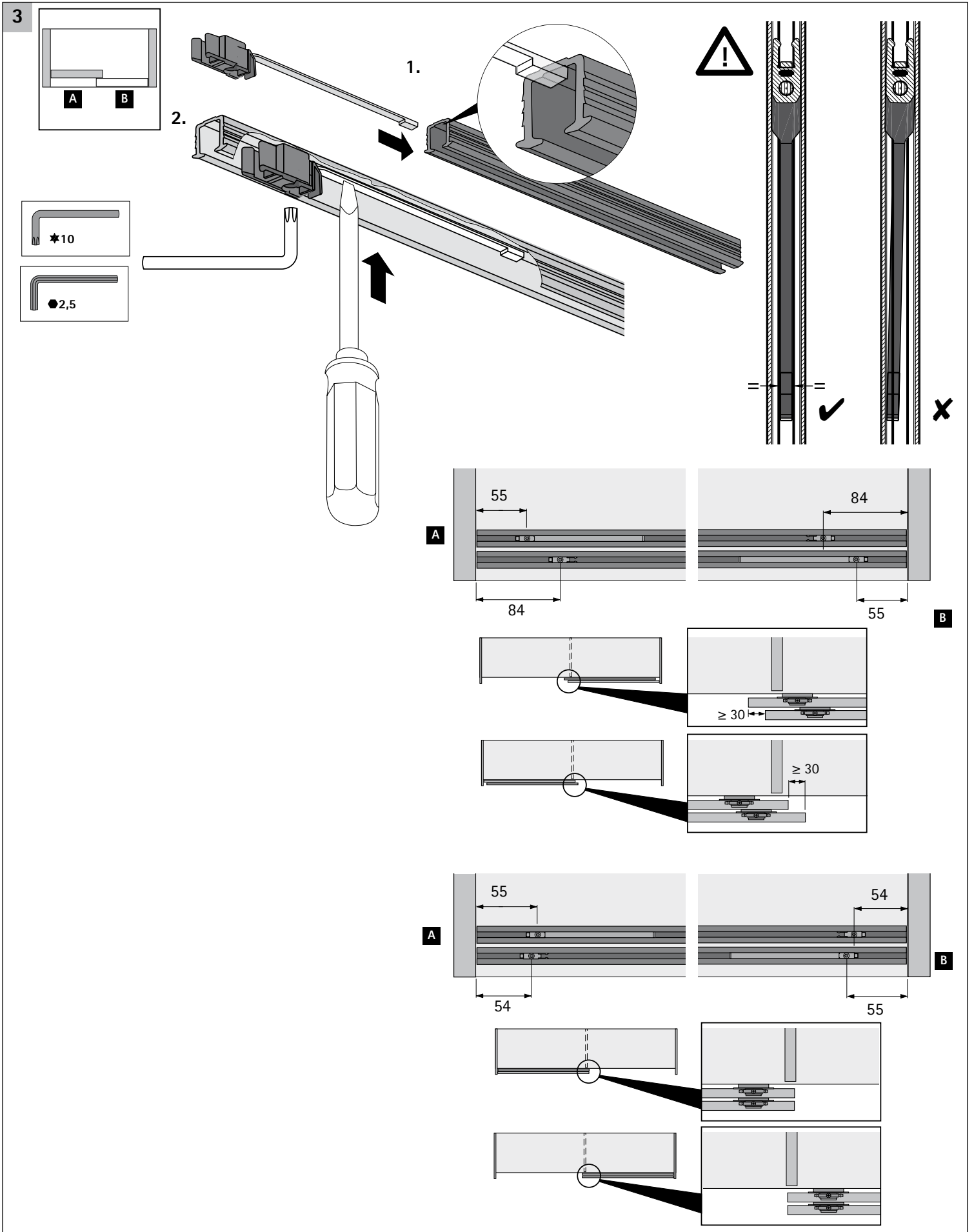

4

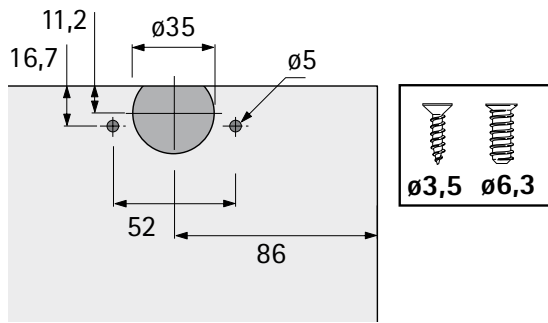

5

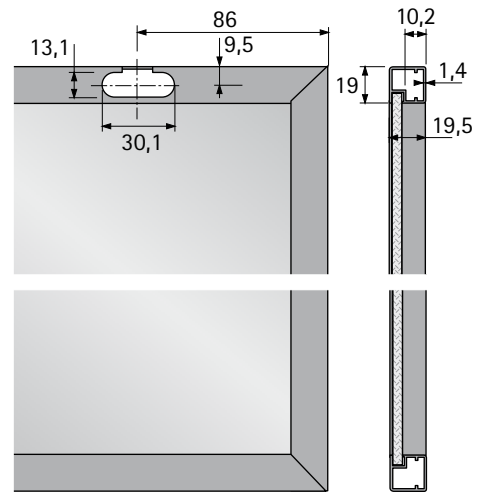

6a

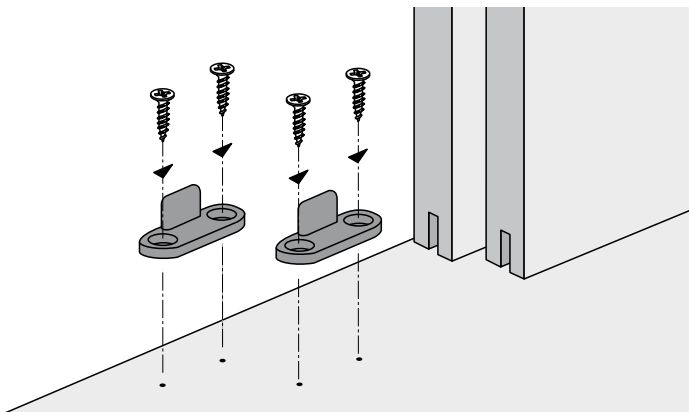

6b

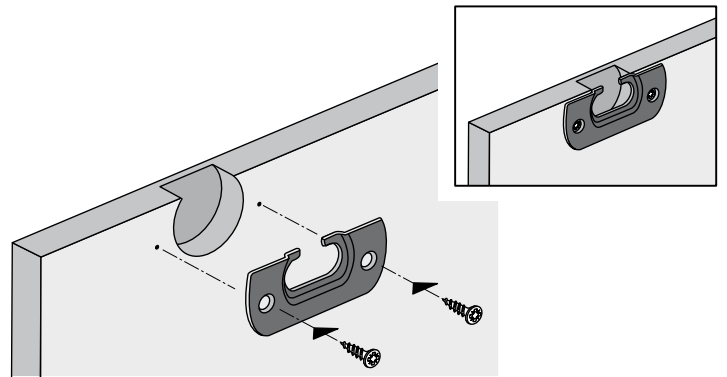

6c

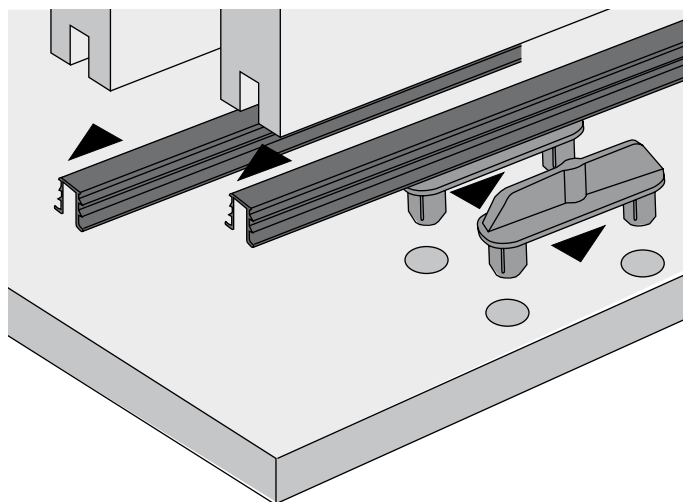

7

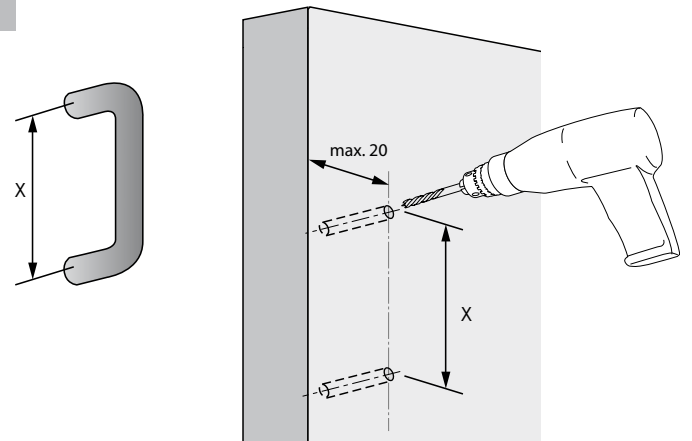

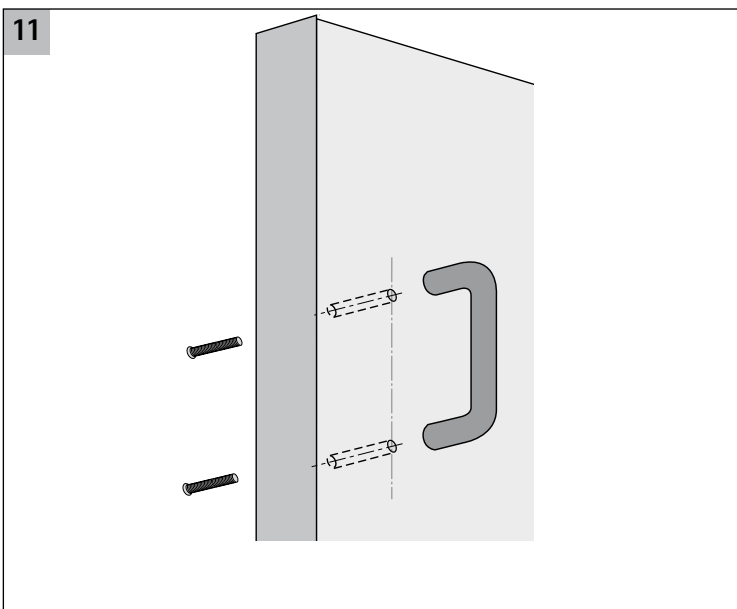
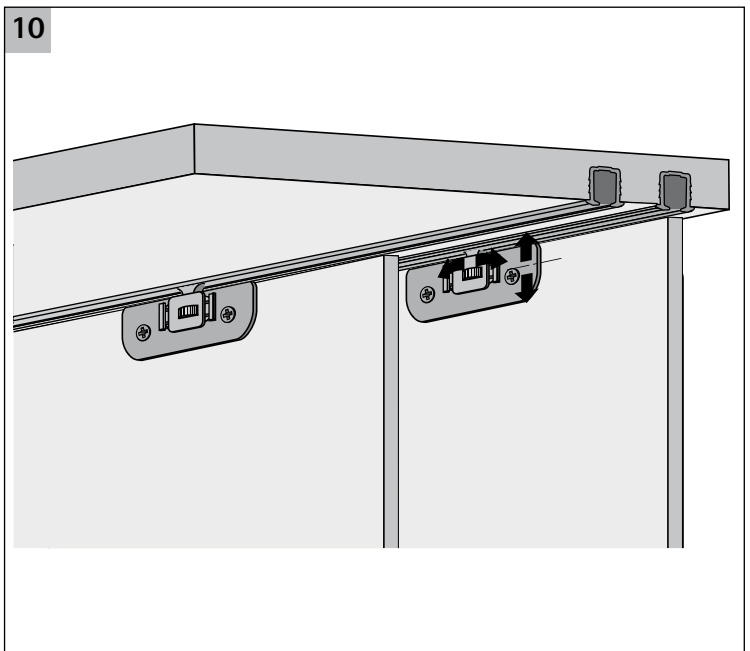
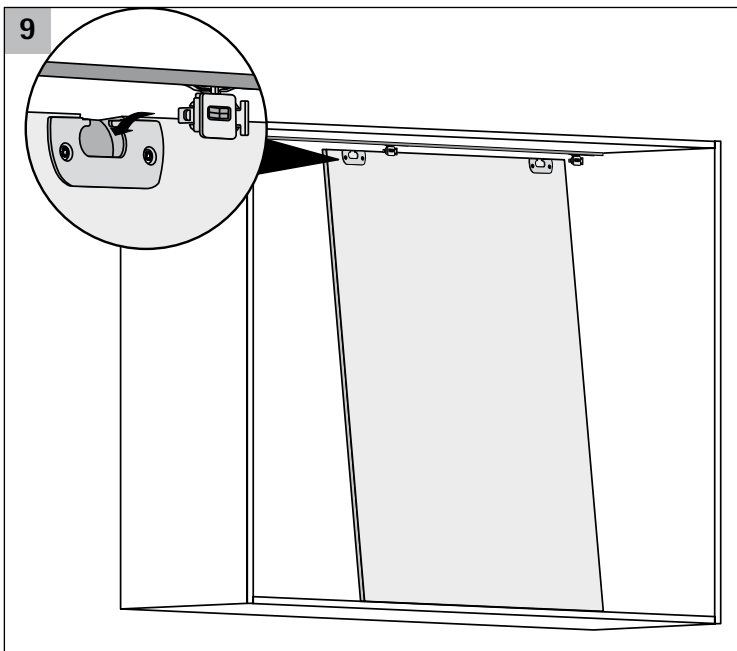
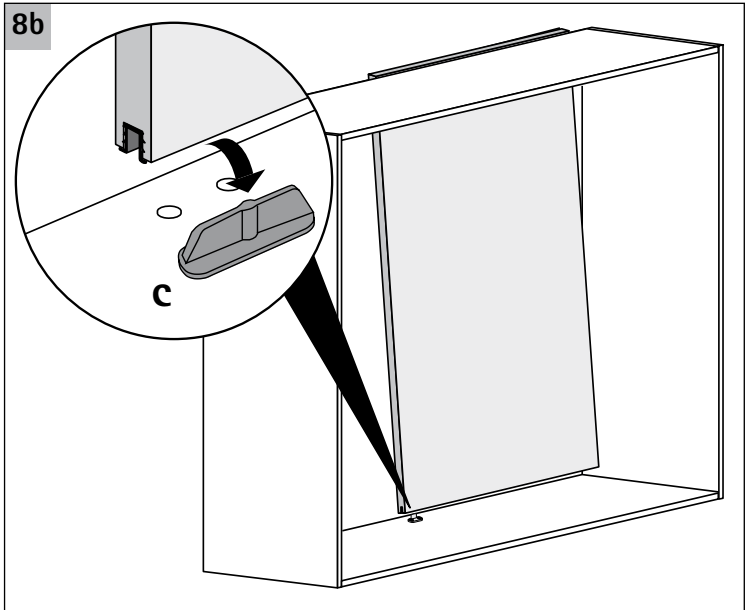
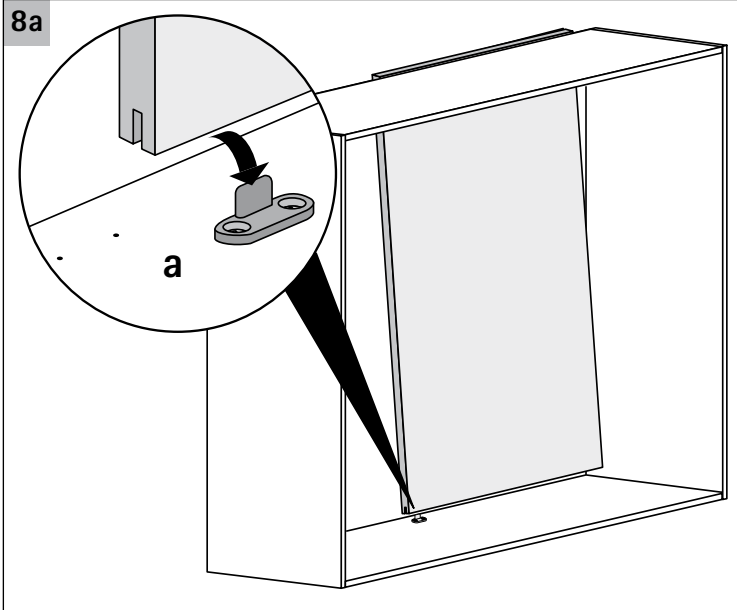

- 12
- D** Zur Aktivierung des Dämpfungssystems die Türen einmal Schließen und Öffnen.
  - GB** To activate the damping system, the doors open and close once.
  - F** Pour procéder à l'activation du système d'amorti, veuillez ouvrir et fermer une première fois les portes.
  - I** Aprire e chiudere le ante una volta per attivare l'ammortizzatore.
  - ES** Hay que proceder a abrir y cerrar las puertas para la activación del sistema de amortiguación.
  - NL** Om het dempingsysteem te activeren de deuren één keer sluiten en openen.
  - PL** Aby aktywować ciche domykanie należy zamknąć i otworzyć drzwi.
  - CS** Pro aktivaci systému tlumení je třeba po montáži zavřít a otevřít dveře.

Technik für Möbel

