

# TopLine XL – Silent System

## **de** Montageanleitung

2-bahniges, obenlaufendes Schiebetürensysteem für großflächige Schiebetüren

## **cz** Montážní návod

Kování pro posuvné dveře, se 2 dráhami a horním nosným profilem

## **dk** Monteringsvejledning

Skydelågesystem med 2 skinner foroven til store skydelåger

## **es** Instrucciones de montaje

Sistema de puertas correderas de 2 pistas y rodadura superior para puertas de gran tamaño.

## **fi** Asennusohje

2-raiteinen, ylhäällä liukuva liukuovi systeemi isoille oville

## **fr** Instructions de montage

Système de portes à 2 voies coulissant par le haut pour les portes coulissantes de grande surface

## **en** Installation instructions

2-track, top running sliding door system for large surface sliding doors

## **it** Istruzioni di montaggio

Dispositivo per ante scorrevoli con guida superiore a 2 binari per ante scorrevoli di grandi dimensioni

## **nl** Montagehandleiding

Bovenaan lopend schuifdeursysteem met 2 banen voor grote schuifdeuren

## **pl** Instrukcja montażu

2-torowy system do drzwi przesuwanych z górnym mechanizmem jezdnym, do frontów o dużych powierzchniach

## **ru** Инструкция по монтажу

2-дорожечная система раздвижных дверей с верхним ходовым элементом для больших дверей

## **se** Monteringsanvisning

2-spårigt, topplöpande skjutdörrssystem för stora skjutdörrar

## **tr** Montaj kılavuzu

2 raylı, büyük boyutlu sürmeli kapaklar için üstten hareketli sürmeli kapak sistemi

## **ko** 설치 설명서

2-레일식, 대형 슬라이딩 도어에 적합한 상부 러닝 슬라이딩 도어 시스템

## **ja** 金具取付けマニュアル

大型引き戸用上レール、2トラックシステム

## **zh** 安装说明

用于大型门体，双轨道，顶部滑动移门系统

Technik für Möbel

**Hettich**



9 169 548



9 181 742

9 181 744

9 183 533

9 183 613

9 183 615

9 183 616

9 183 617



2 - 6



7 - 11

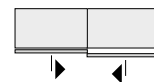

12 - 25



26



### **de** Bestimmungsgemäße Verwendung

Der Möbelbeschlag TopLine XL wird für obenlaufende Schiebetürsysteme verwendet.

Er ist für die Verwendung in Möbeln nach EN 14749 und den Einsatz in geschützten, trockenen Innenräumen vorgesehen.

Eine andere als die unter „Bestimmungsgemäße Verwendung“ festgelegte Verwendung gilt als nicht bestimmungsgemäß.

Der Beschlag ist getestet nach EN 15706, Level 3.

Es wird empfohlen, den Schrank gegen Kippen zu sichern.

### **cz** Použití v souladu s určením

Nábytkové kování TopLine XL se používá pro systémy posuvných dveří s horním nosným profilem.

Je určeno do nábytku podle EN 14749 a pro použití v chráněných a suchých interiérech.

Jiné použití, než které je definované pod bodem „Použití v souladu s určením“, se považuje za nesprávné.

Kování je testováno podle EN 15706, úroveň 3.

Doporučuje se zajistit skříň proti překlopení.

### **dk** Tilsigtet brug

Møbelbeslaget TopLine XL anvendes til skydelågesystemer, der kører foroven.

Det er beregnet til anvendelse i møbler i overensstemmelse med EN 14749 og til brug i beskyttede, tørre indendørs lokaler.

Anden brug end den, der er fastlagt under „Tilsigtet brug“, betragtes som utilsigtet brug.

Beslaget er testet iht. EN 15706, level 3.

Det anbefales at sikre skabet mod at vælte.

### **es** Utilización conforme al uso previsto

El herraje de mueble TopLine XL se utiliza para sistemas de puerta corredera con deslizamiento superior.

Está previsto para el uso en muebles según EN 14749 y su aplicación en estancias protegidas y secas.

Cualquier otra utilización que difiera de la „Utilización conforme al uso previsto“ se considera no conforme a lo previsto.

El herraje ha sido verificado conforme a EN 15706, nivel 3.

Se recomienda asegurar el armario para evitar que pueda volcar.

### **fr** Utilisation conforme à la destination prévue

La ferrure de meuble TopLine XL est utilisée pour les systèmes de portes coulissant par le haut.

Elle est prévue pour une utilisation dans des meubles conformément à la norme EN 14749 et, à l'intérieur, dans des pièces non humides et protégées.

Toute utilisation autre que celle indiquée dans l'« utilisation conforme à la destination prévue » est considérée non-conforme.

La ferrure est testée selon la norme EN15706, niveau 3.

Il est conseillé de sécuriser l'armoire pour éviter qu'elle ne bascule.

### **fi** Käyttötarkoitus

TopLine XL -huonekaluhelaa käytetään ylhäällä kulkevissa liukuovijärjestelmissä.

Se on tarkoitettu käytettäväksi huonekaluissa EN 14749 -standardin mukaisesti ja sitä voidaan käyttää suojatuissa, kuivissa sisätiloissa.

Kaikenlainen muu kuin „käyttötarkoituksen mukainen“ käyttö ei ole käyttötarkoituksen mukaista käyttöä.

Hela on testattu EN 15706 -standardin, taso 3, mukaisesti.

Kaappi kannattaa varmistaa kaatumista vastaan.

### **en** Intended Use

The TopLine XL furniture fitting is used for top running sliding door systems. It is intended for application in furniture to EN14749 and use in dry indoor environments where it is protected from the elements.

Any use other than that defined under „Intended Use“ will be deemed to be non-intended use.

The fitting is tested to EN 15706, Level 3.

It is recommended to prevent the cabinet from toppling over.

### **it** Uso conforme alla destinazione

Il dispositivo per mobili TopLine XL viene utilizzato come sistema per ante scorrevoli su binario superiore.

Il suo uso è previsto in mobili conformi alla norma EN 14749 e in ambienti interni protetti e asciutti.

Ogni altro utilizzo diverso da quanto indicato al punto “Uso conforme alla destinazione” viene considerato non conforme.

Il sistema è testato secondo la EN 15706, Level 3.

Si consiglia di fissare il mobile per evitare che si ribalti.

**(nl) Doelmatig gebruik**

Meubelbeslag TopLine XL wordt voor bovenaan lopende schuifdeur systemen gebruikt.  
 Het is gemaakt voor gebruik in meubels volgens EN 14749 en toepassing in beschutte, droge binnenruimtes.  
 Elk ander gebruik dan vastgelegd onder 'Doelmatig gebruik' geldt als zijnde niet volgens de voorschriften.  
 Het beslag werd getest volgens EN 15706, level 3.  
 Wij adviseren de kast te beveiligen tegen kantelen.

**(pl) Zastosowanie zgodne z przeznaczeniem**

Okucie meblowe TopLine XL stosowane jest w systemach do drzwi przesuwnych z górnym mechanizmem jezdny.  
 Przeznaczone jest do zastosowania w meblach zgodnie z EN 14749 oraz do zastosowania w osłoniętych, suchych pomieszczeniach wewnętrznych.  
 Zastosowanie inne niż określone jako „Zastosowanie zgodne z przeznaczeniem” jest niezgodne z przeznaczeniem.  
 Okucie zostało przetestowane zgodnie z EN 15706, poziom 3.  
 Zaleca się zabezpieczyć szafy przed przewróceniem się.

**(ru) Использование по назначению**

Фурнитура TopLine XL предназначена для использования в конструкциях с раздвижными дверями с верхним ходовым элементом.  
 Она предусмотрена для использования в мебели по стандарту EN 14749 и для применения в защищенных, сухих внутренних помещениях.  
 Иное применение, кроме указанного в разделе „Использование по назначению”, считается использованием не по назначению.  
 Фурнитура испытана по стандарту EN 15706, уровень 3.  
 Рекомендуется принять меры против опрокидывания шкафа.

**(se) Ändamålsenlig användning**

Möbelbeslaget TopLine XL används för toplöpande skjutdörrssystem.  
 Det är tillverkat för att användas i möbler enligt EN 14749, i skyddade, torra utrymmen inomhus.  
 En annan användning än den som fastställts med „Ändamålsenlig användning”, anses som icke ändamålsenlig.  
 Beslaget är testat enligt EN 15706, nivå 3.  
 Det rekommenderas att säkra skåpet mot att välta.

**(tr) Amacına uygun kullanım**

Mobilya aksesuarı TopLine XL, üstten hareketli sürmeli kapak sistemleri için kullanılır. EN 14749 standardına uygun, kuru ve korunaklı iç mekan mobilyalarında kullanım için öngörülmüştür.  
 „Amacına uygun kullanım” başlığı altında öngörülenin dışındaki bir kullanım, amacına aykırı olarak nitelendirilir.  
 Aksesuar, EN 15706, Seviye 3 uyarınca test edilmiştir.  
 Dolabın, devrilmeye karşı emniyete alınması önerilir.

**(ko) 사용용도**

TopLine XL은 상부 러닝방식의 슬라이딩 도어 시스템입니다. EN14749에 따라 인증된 가구용 피팅으로서 손상을 방지하기 위해 건조한 실내에서 사용해야 합니다. 제시된 목적 이외의 용도에는 사용할 수 없습니다. 이 피팅은 EN 15706, Level 3에 따라 테스트 완료 하였습니다. 설치시 수납장을 넘어뜨리지 않도록 유의하시기 바랍니다.

**(ja) 用途**

トップラインXLは吊り戸タイプの引き戸金物です。  
 上部レールで支える吊り戸タイプです。  
 通常の屋内(異常な高湿度及び温度ではない環境)に設置される家具以外での使用には  
 適しません。  
 この金具はヨーロッパ品質基準EN 15706のレベル3の試験をパスしています。  
 家具本体は転倒せぬよう必ず建築躯体に固定してください。

**(zh) 用途**

TopLine XL 家具配件应用于顶部滑动的移门系统。专为符合 EN 14947 标准定义的干燥室内环境下使用的家具而设计。  
 在非上述标准定义的环境中使用此配件将被视为“非正常使用”。  
 配件符合 EN 15706 三级标准。  
 为防止柜体倾覆，建议从柜体顶部将其固定至墙面。



[www.hettich.com/short/30c73a](http://www.hettich.com/short/30c73a)

#### Erweiterte Montageanleitung als Download

Sie benötigen eine ausführlichere Montageanleitung? Kein Problem! Wir haben zusätzliche Tipps und Informationen in Ihrer Sprache zusammengestellt, um Ihnen die Montage zu erleichtern. Hier können Sie die erweiterte Anleitung herunterladen.

#### Rozšířený montážní návod ke stažení

Potřebujete podrobnější montážní návod? Žádný problém! Jsou k dispozici další informace a doporučení pro usnadnění montáže. Rozšířený návod můžete stáhnout zde.

#### Udvidet monteringsvejledning som download

Har du brug for en mere udførlig monteringsvejledning? Det er ikke noget problem! Vi har samlet ekstra tips og oplysninger på dit sprog for at gøre monteringen lettere for dig. Her kan du downloade den udvidede vejledning.

#### Instrucciones de montaje ampliadas disponibles para su descarga

¿Necesita unas instrucciones de montaje detalladas? ¡Ningún problema! Hemos recopilado información y consejos complementarios en su idioma para facilitarle el montaje. Aquí puede descargar las instrucciones ampliadas.

#### Instructions de montage approfondies à télécharger

Avez-vous besoin d'instructions de montage plus approfondies? Pas de problème! Nous avons réuni des astuces et des informations supplémentaires dans votre langue pour vous faciliter le montage. Vous pouvez télécharger ici les instructions approfondies.

#### Detailed installation instructions for downloading

Do you need installation instructions of a more detailed nature? Not a problem. We have put together some additional advice and information in English that will make installation easier for you. The more detailed instructions are available for downloading here.

#### Gelişmiş montaj talimatı

Detaylı montaj talimatına mı ihtiyacınız var? Problem değil! Montajınızı kolaylaştırmak için anadilinizde, birçok faydalı öneri ve bilgiyi bir araya topladık. Buradan gelişmiş montaj talimatını indirebilirsiniz.

#### Download istruzioni di montaggio ampliate

Vi servono istruzioni di montaggio più dettagliate? Nessun problema! Abbiamo raccolto ulteriori consigli e informazioni nella vostra lingua per facilitarvi le operazioni di montaggio. Qui potete scaricare le versioni ampliate delle istruzioni.

#### Utførlig monteringsanvisning att ladda ner

Behöver du en utførlig monteringsanvisning? Inget problem! Vi har samlat ihop extra tips och information på ditt eget språk för att underlätta monteringen. Här kan du ladda ner anvisningen.

#### Uitgebreide montagehandleiding on te downloaden

U heeft een uitgebreidere montagehandleiding nodig? Geen probleem! Wij hebben bijkomende tips en informatie in uw taal samengesteld om de montage makkelijker te maken. Hier kan u de uitgebreide handleiding downloaden.

#### Rozszerzona instrukcja montażu w formie pliku do pobrania

Potrzebujecie Państwo jeszcze bardziej szczegółowej instrukcji montażu? To żaden problem! Przygotowaliśmy w Państwa języku dodatkowe wskazówki i informacje, które ułatwią Państwu montaż. Tutaj możecie Państwo pobrać rozszerzoną instrukcję.

#### Расширенная инструкция по монтажу для скачивания

Вам нужна расширенная инструкция по монтажу? Нет ничего проще! Мы собрали дополнительные рекомендации и информацию на вашем языке, чтобы облегчить вам монтаж. Здесь вы можете загрузить расширенную инструкцию.

#### Ladattava laajennettu asennusohje

Tarvitset seikkaperäisemmän asennusohjeen? Ei ongelma! Olemme koonneet suomeksi käännettyjä lisävinkkejä ja -tietoja, jotka helpottavat asennusta. Voit ladata laajennetun ohjeen tästä.

#### 설치 설명서 다운로드

자세한 설치 설명서가 필요하십니까? 문제 없습니다. 더욱 쉽게 설치할 수 있도록 한국어 설치 설명서가 준비되어 있습니다. 여기서 설치 설명서를 다운받을 수 있습니다.

#### より詳細な情報のダウンロード

インラインXL引き戸金具のより詳しい説明が必要な場合は、ここからダウンロードしてください。

#### 下载详细安装说明

您需要更为详尽的安装说明吗? 没问题。我们总结了相关的安装建议与说明并提供中文版本供您参考, 令您的安装更为简单。您可在此下载更多相关详细安装说明。

Click the button to choose your language:



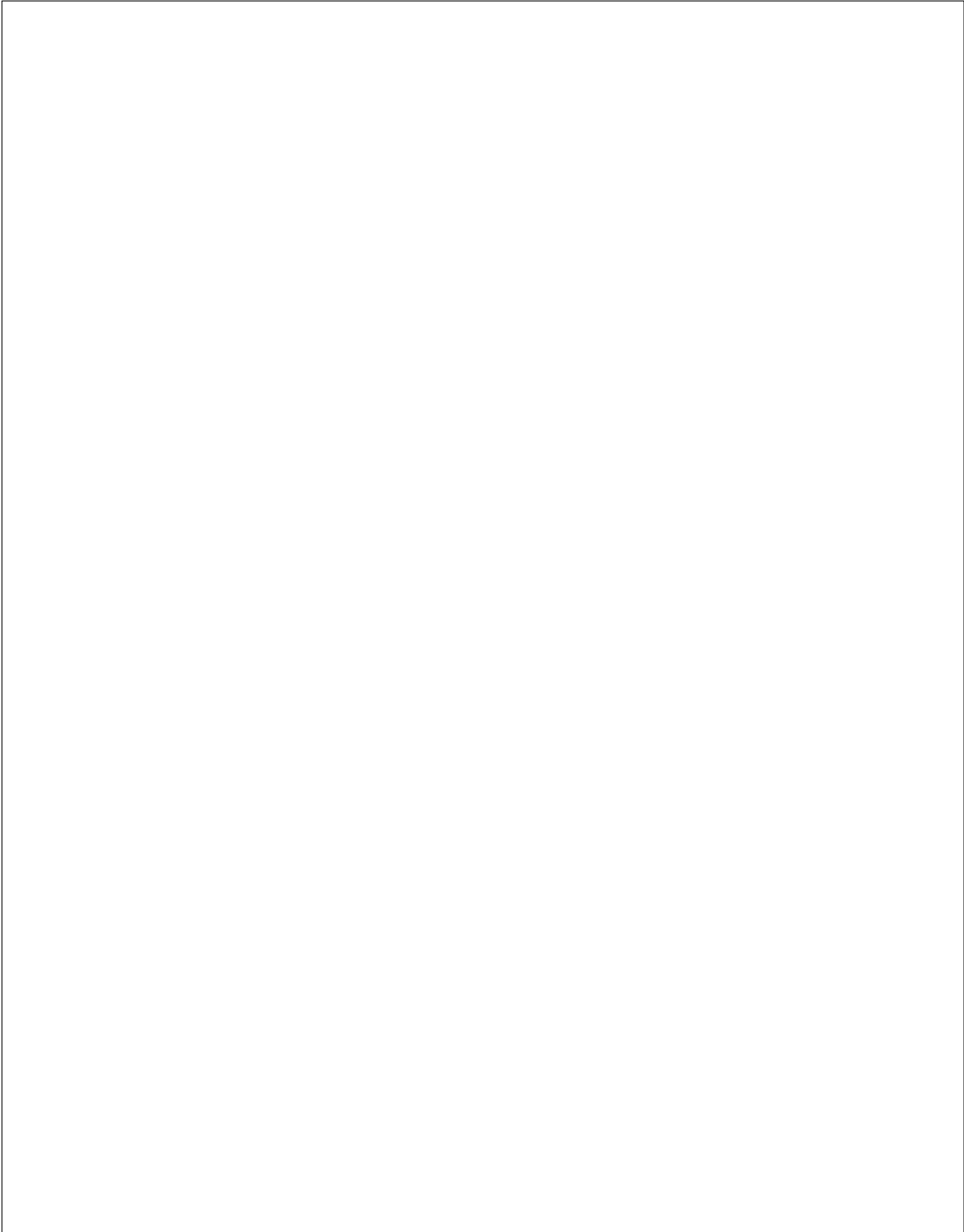

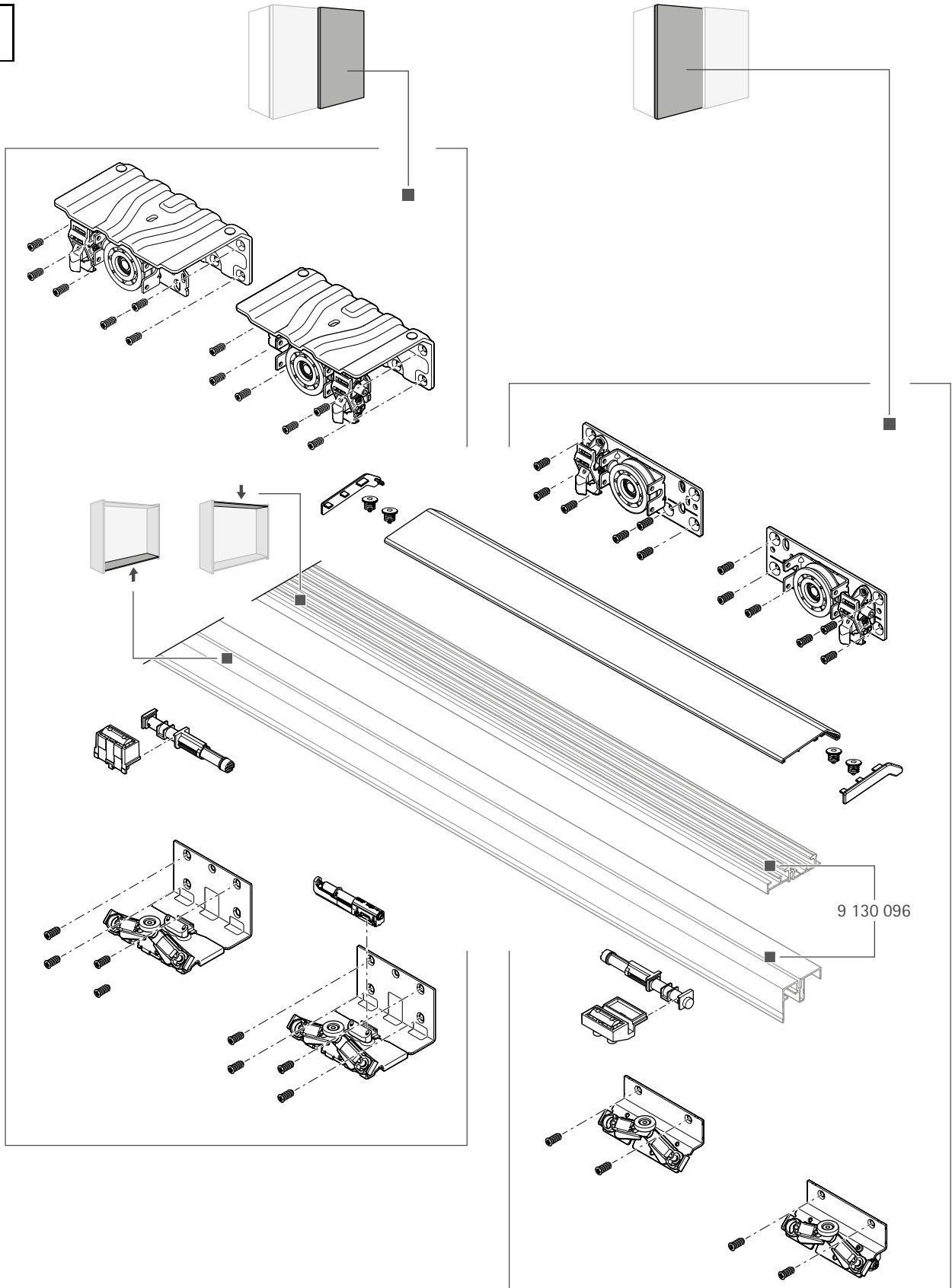

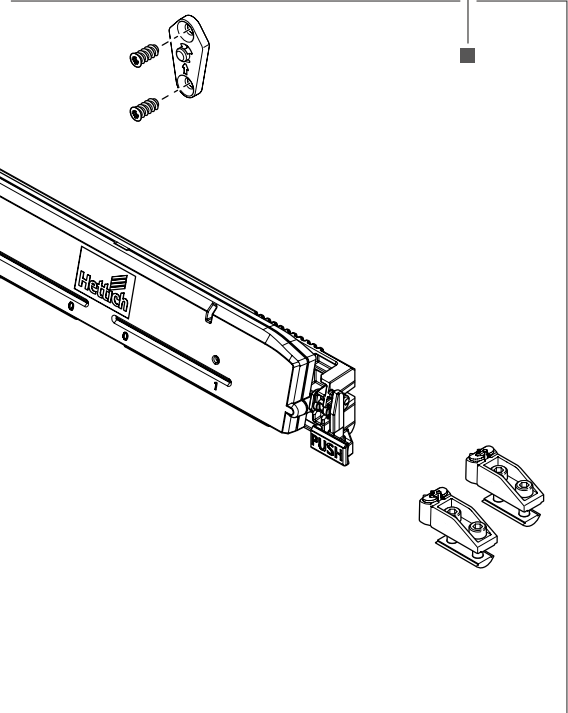
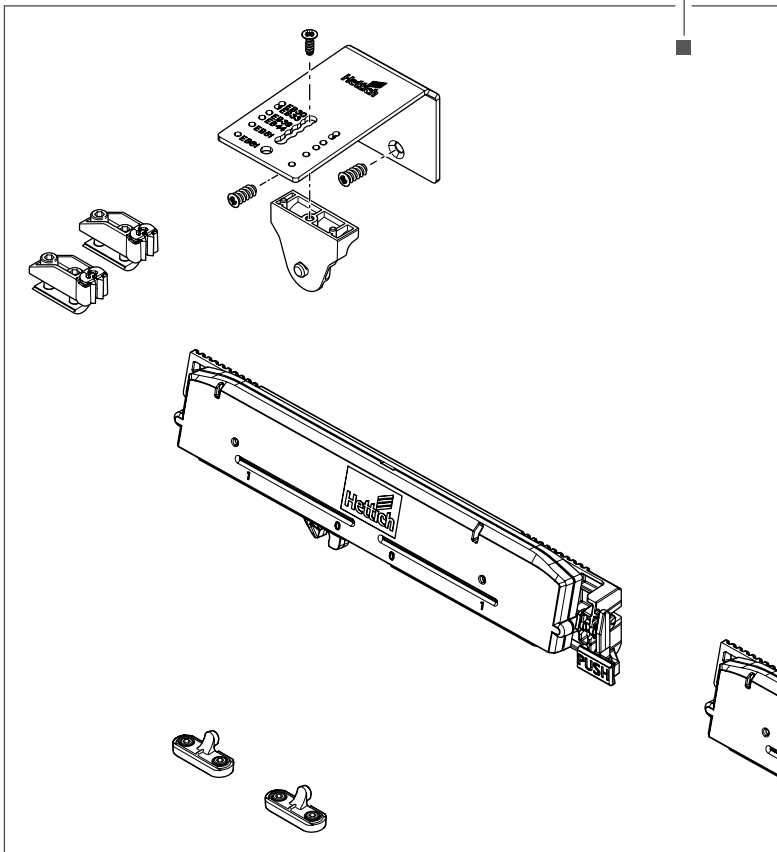
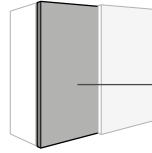
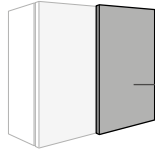
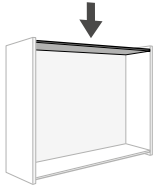

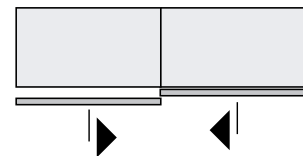
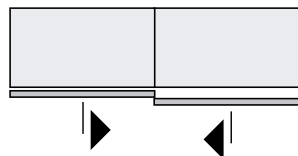
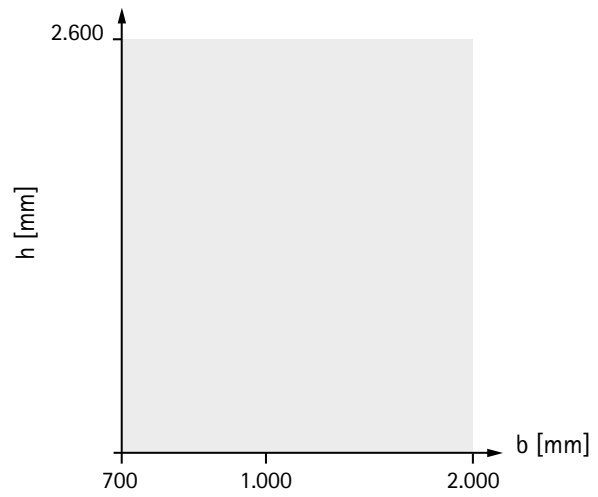
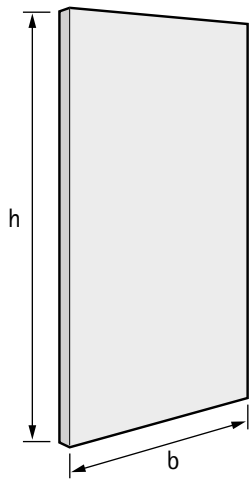
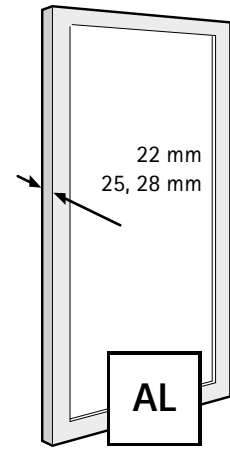
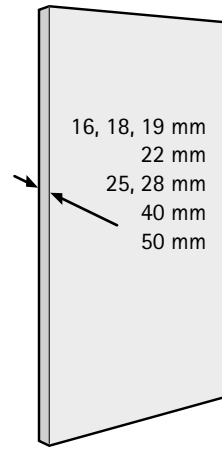
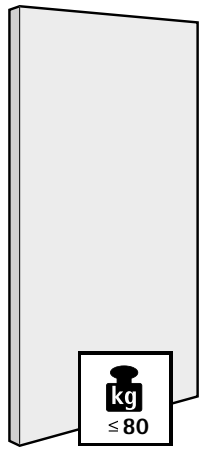



W	EB	X	Y	Z
16 / 18 / 19	30	14 / 12 / 11	9 / 7 / 6	14
22	33	11	6	14
28	39	11	6	14
30 / 32 / 33	44	14 / 12 / 11	9 / 7 / 6	14
40	51	11	5	15
50	61	11	5	15

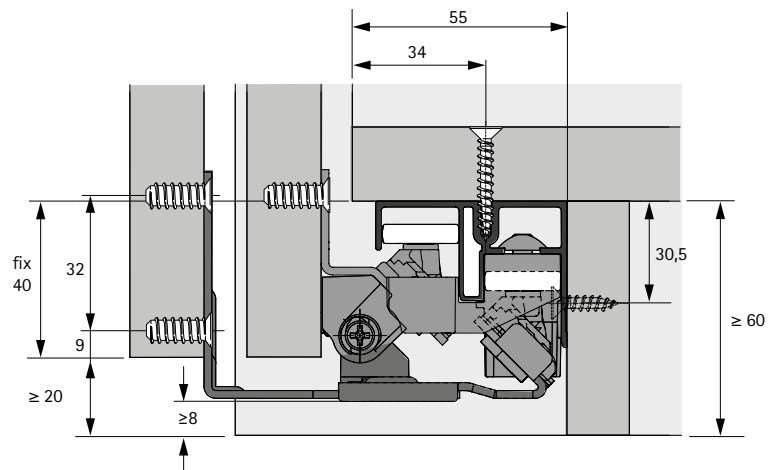
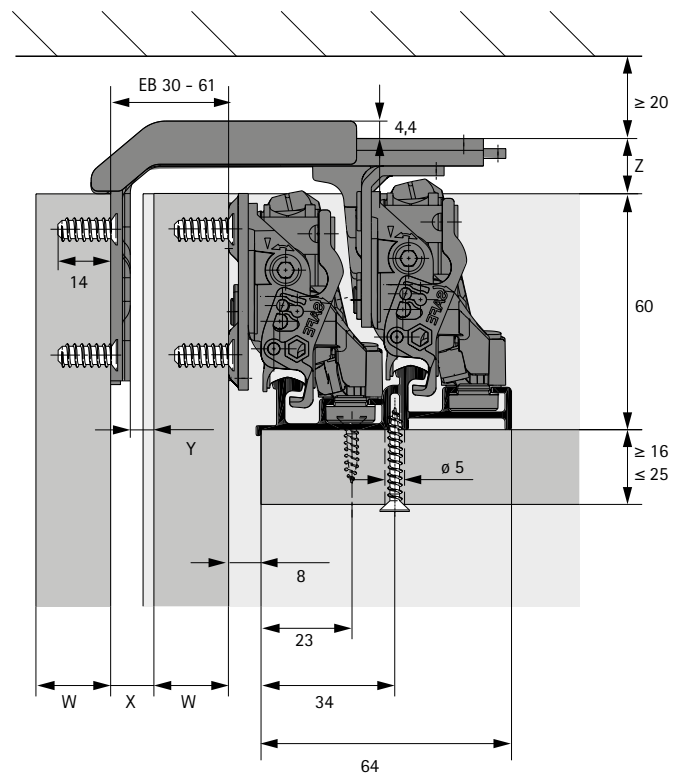
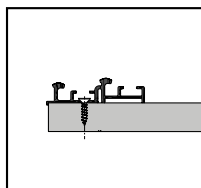
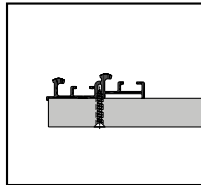
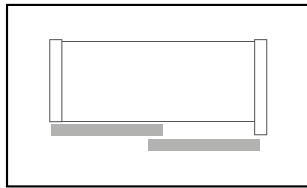

W	EB	X	Y	Z
16 / 18 / 19	30	14 / 12 / 11	9 / 7 / 6	14
22	33	11	6	14
28	39	11	6	14
30 / 32 / 33	44	14 / 12 / 11	9 / 7 / 6	14
40	51	11	5	15
50	61	11	5	15

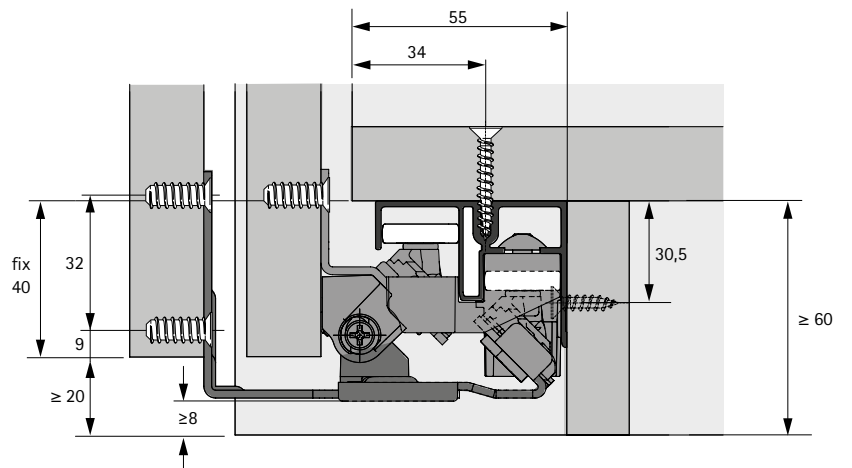
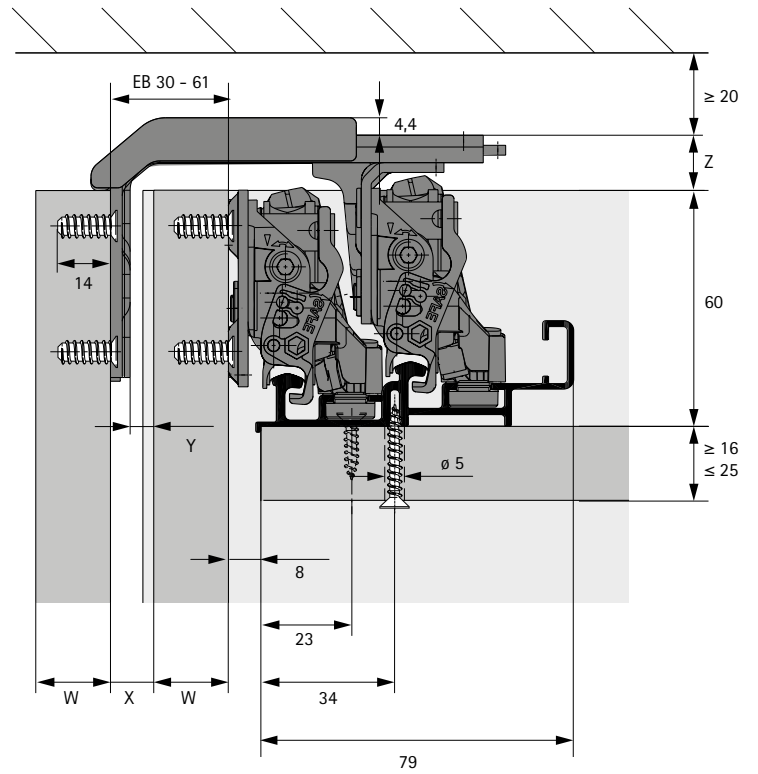
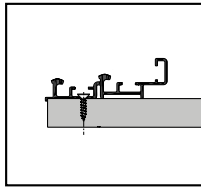
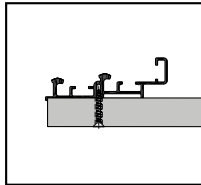
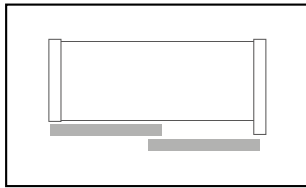

W	EB	X	Y	Z
16 / 18 / 19	30	14 / 12 / 11	9 / 7 / 6	14
22	33	11	6	14
28	39	11	6	14
30 / 32 / 33	44	14 / 12 / 11	9 / 7 / 6	14
40	51	11	5	15
50	61	11	5	15

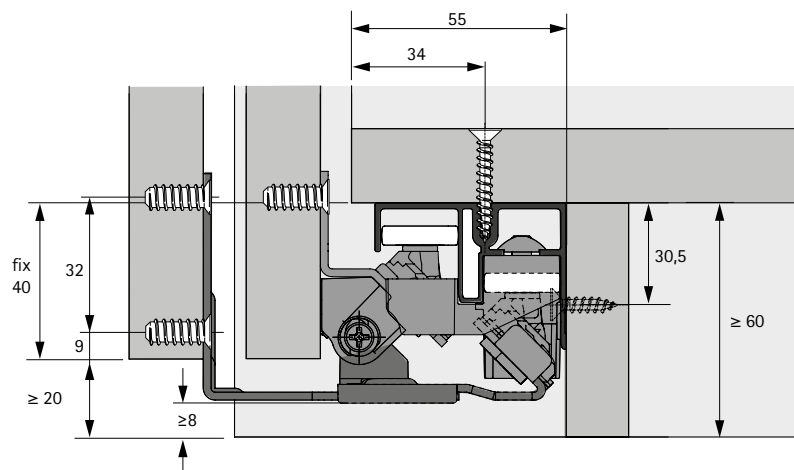
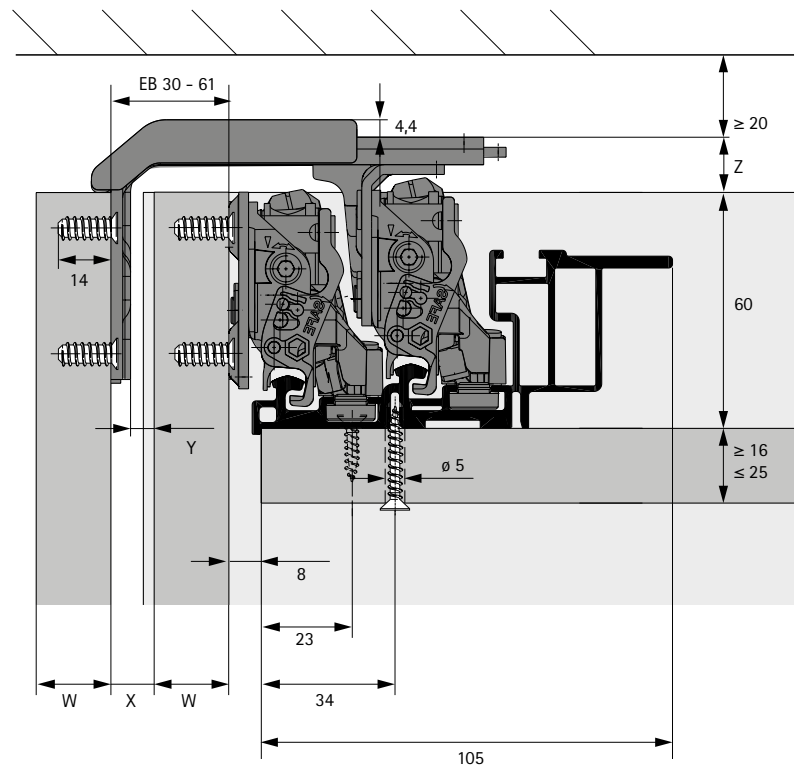
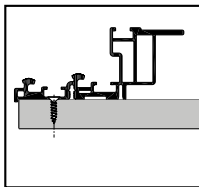
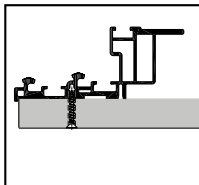
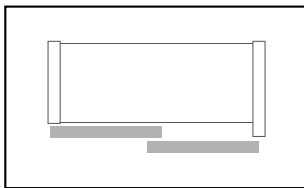

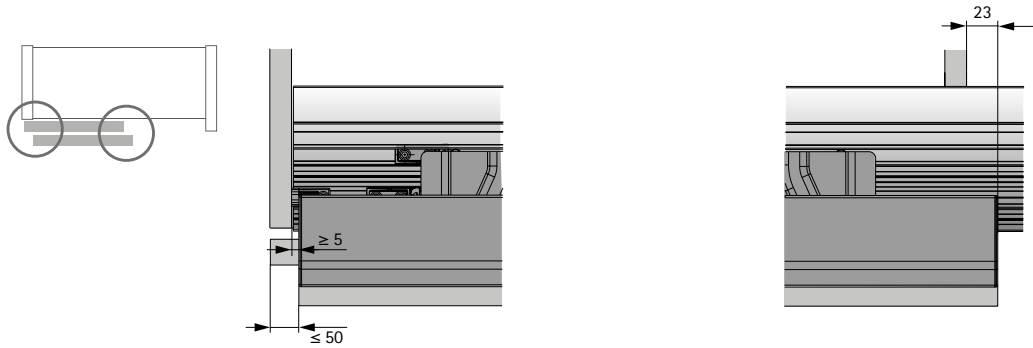
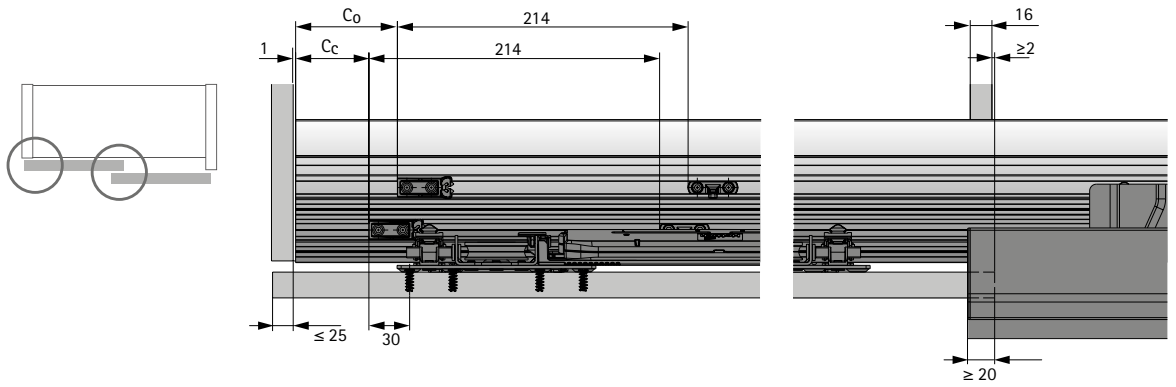
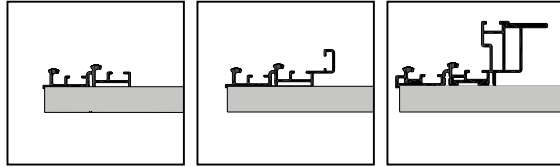
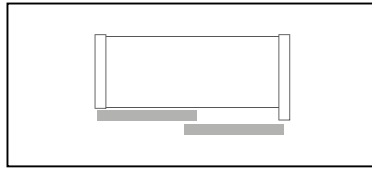

**i**

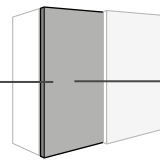
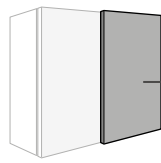

Silent System

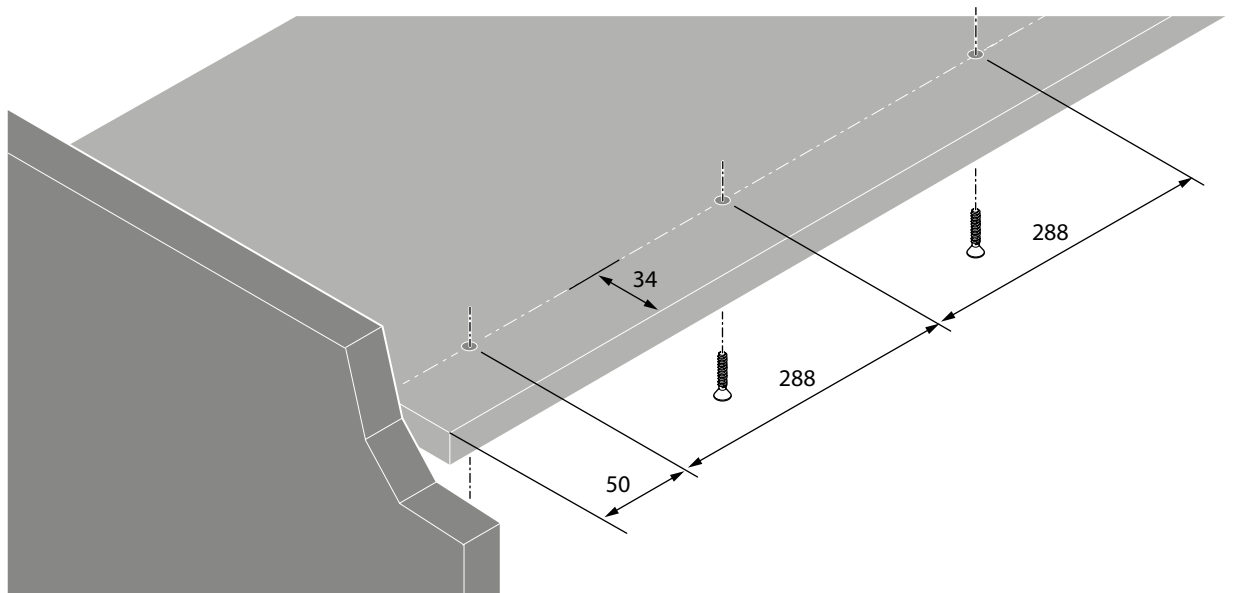
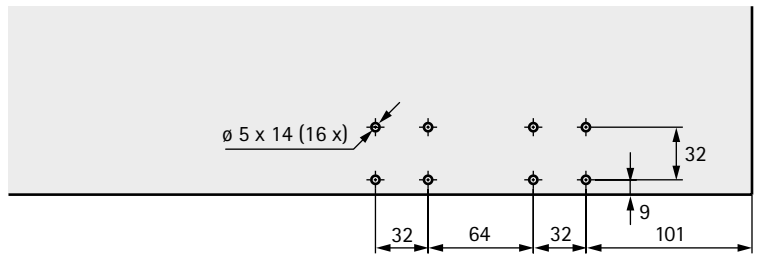
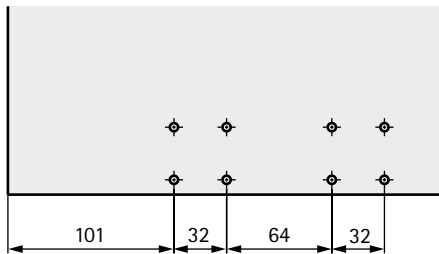
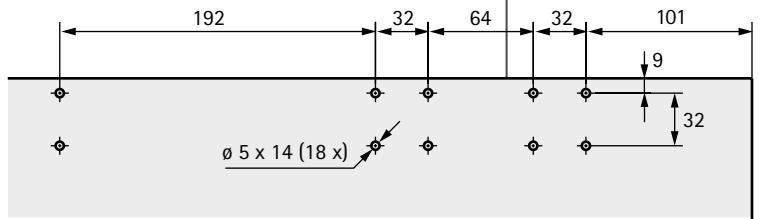
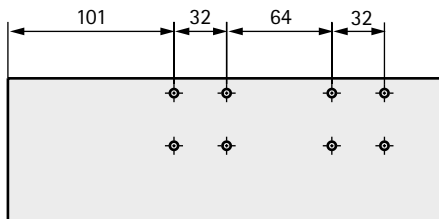

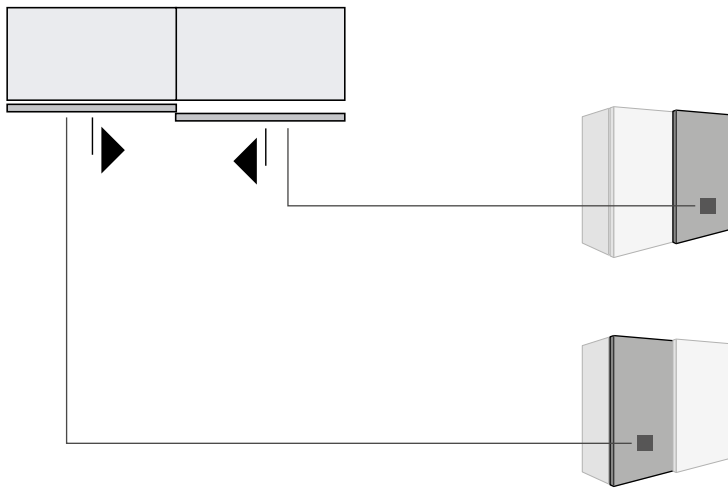

Silent System

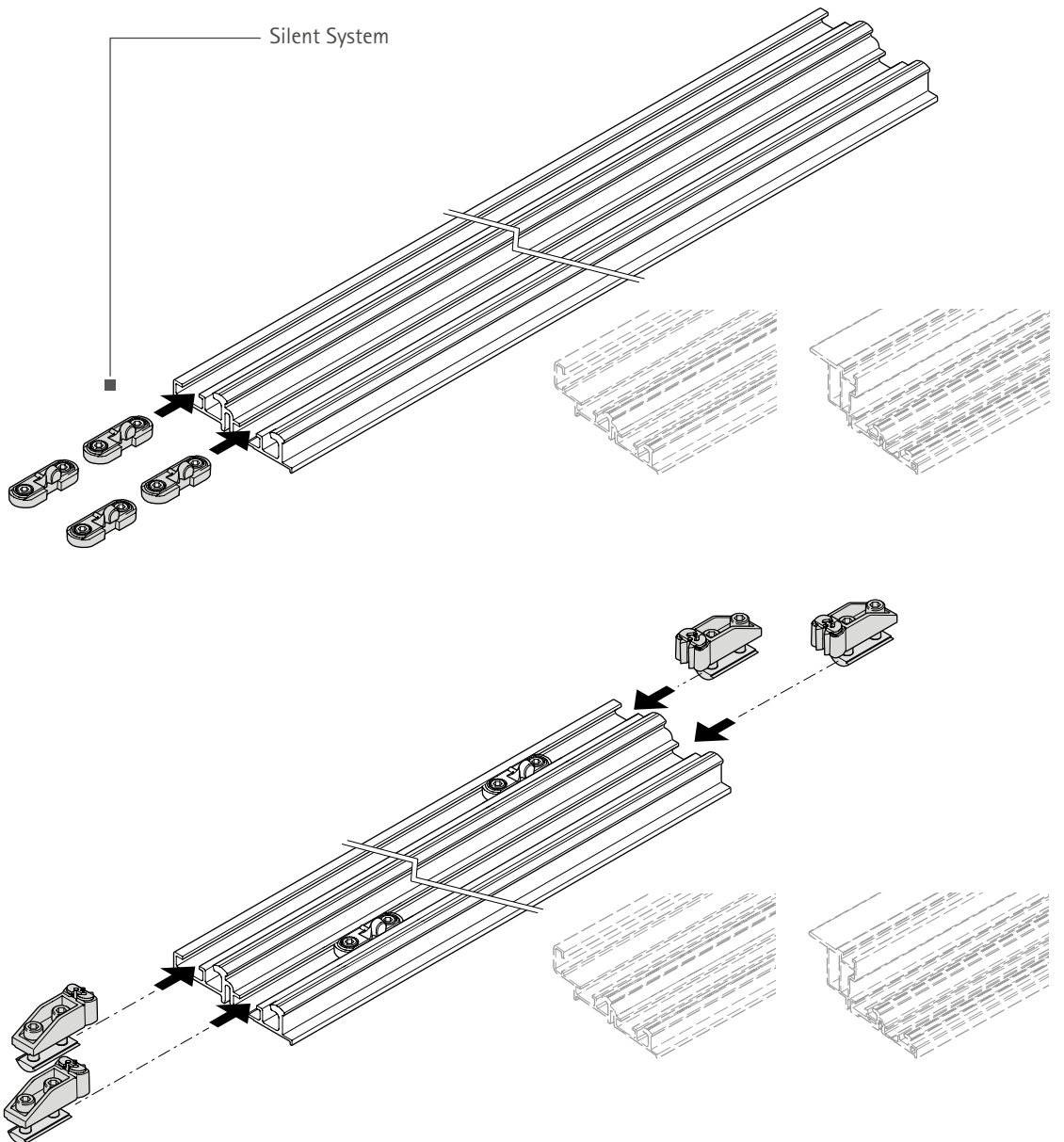

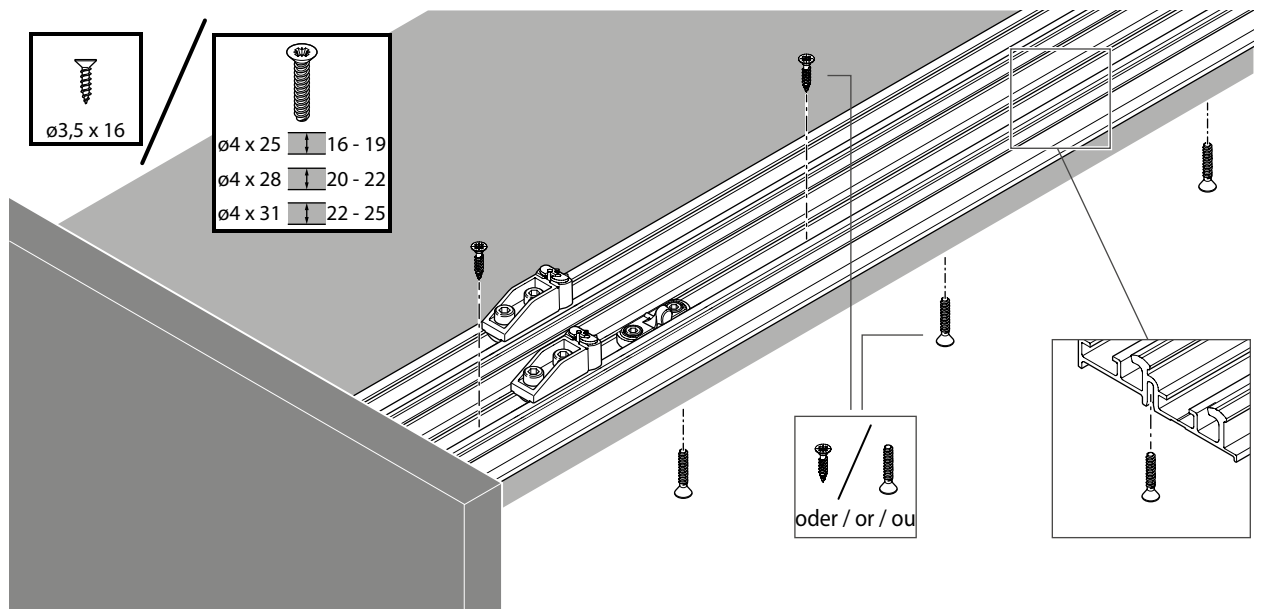
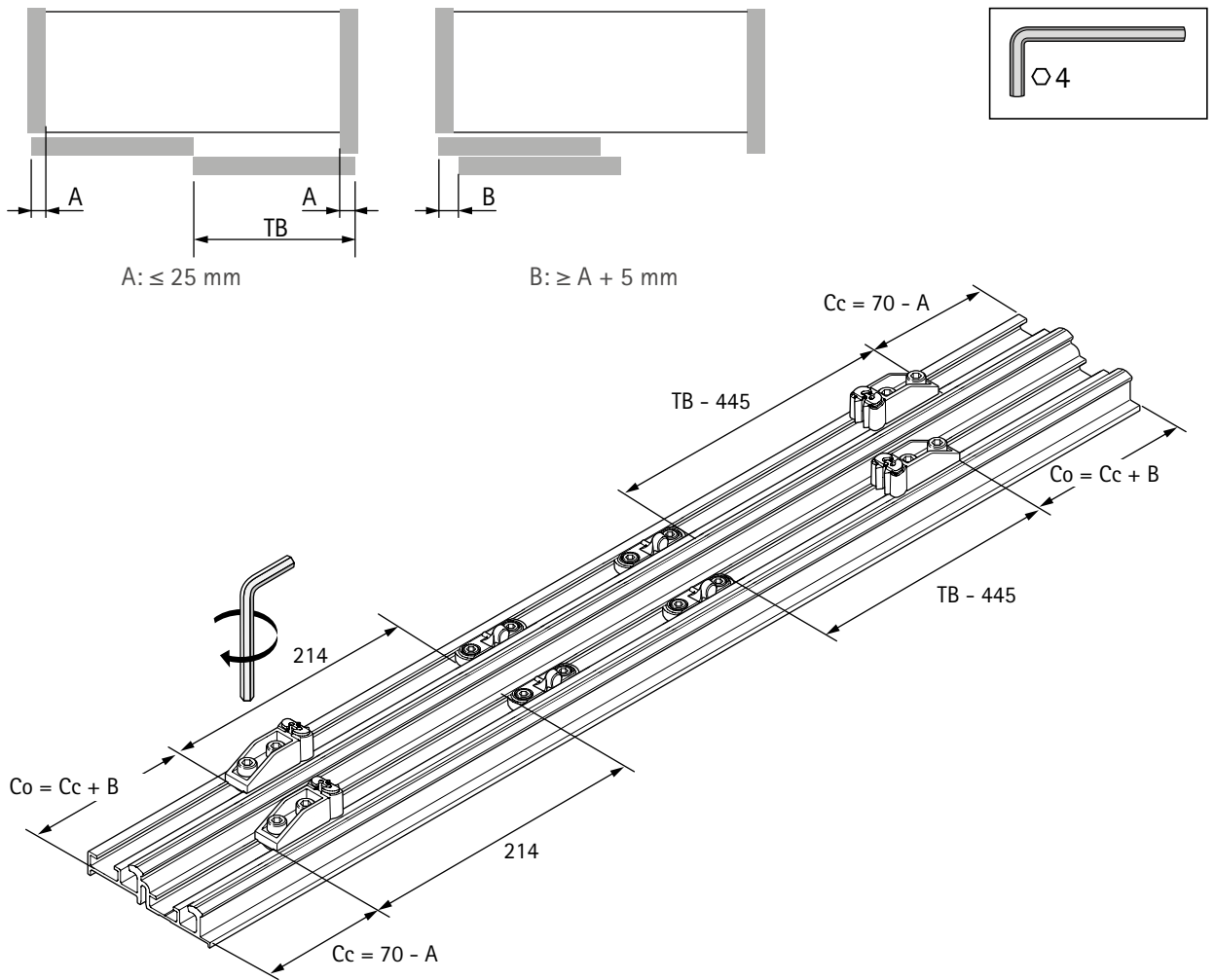

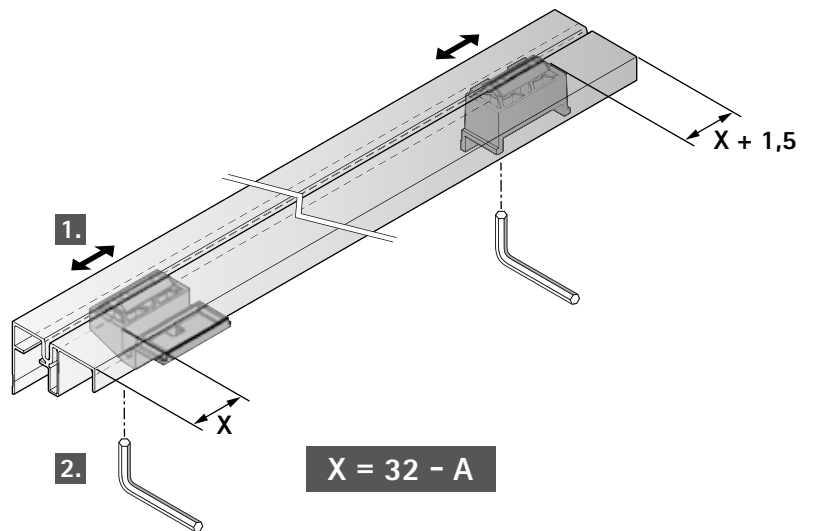
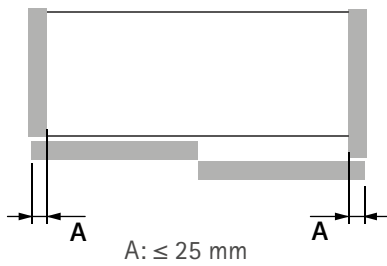
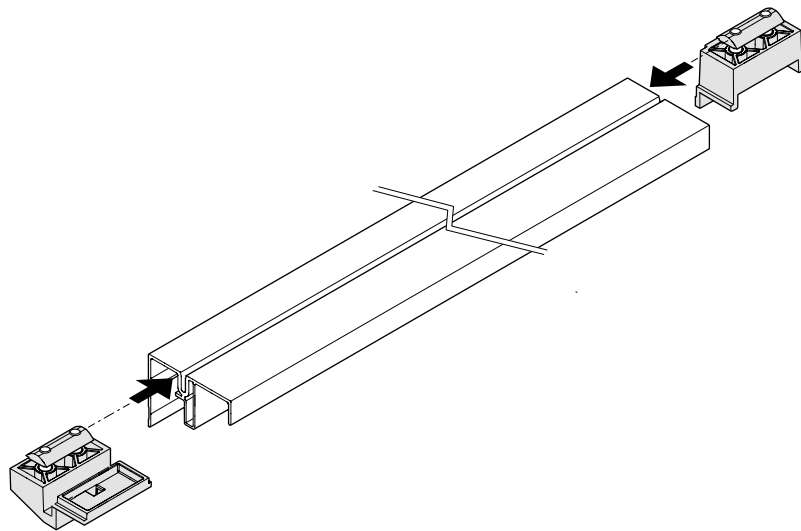
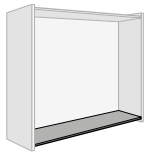

$X = 32 - A$

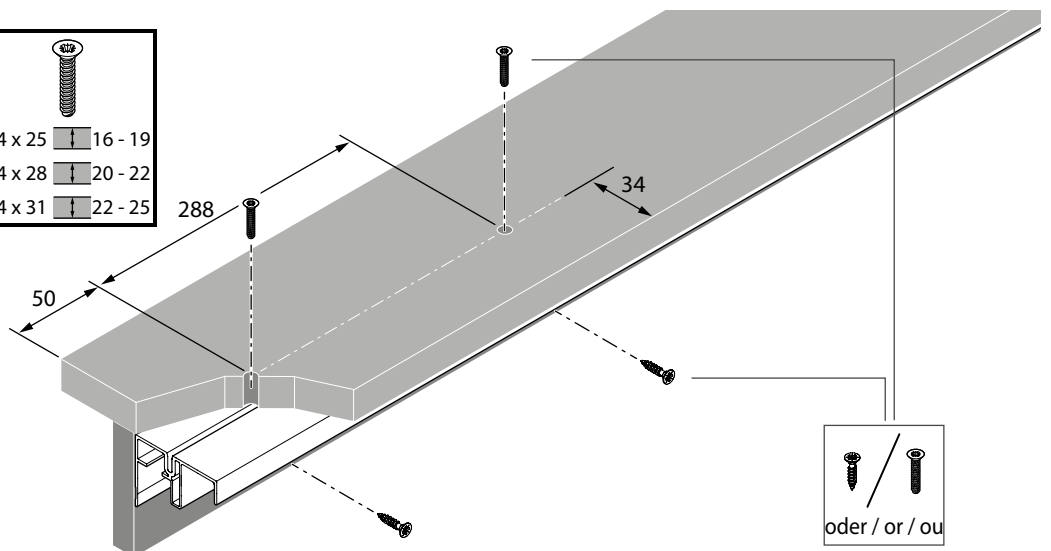
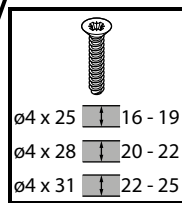
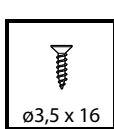



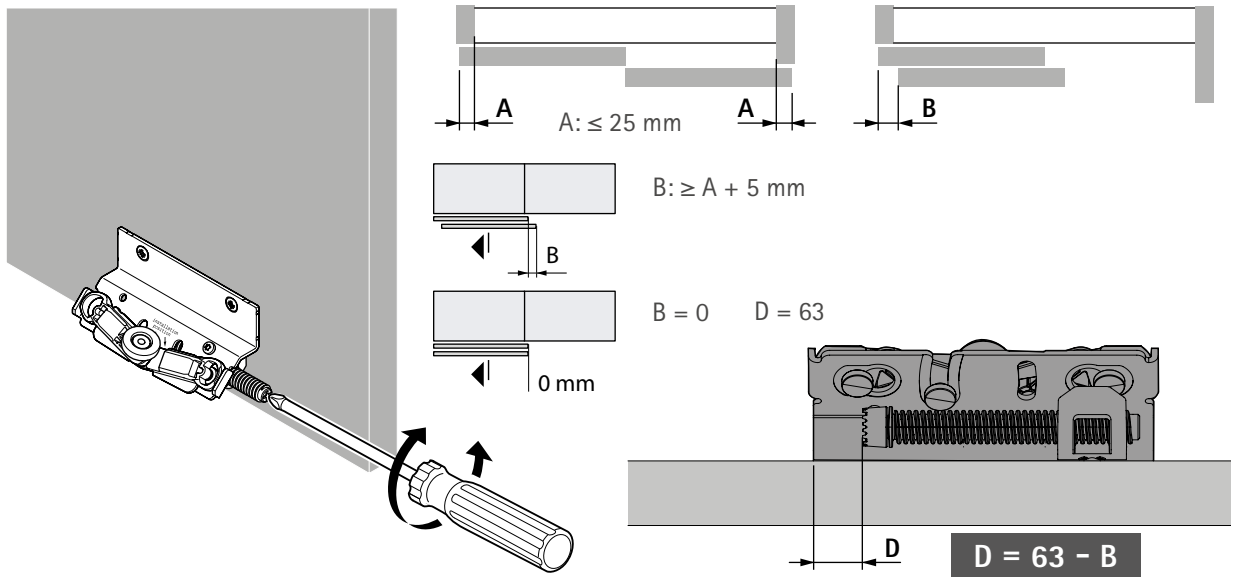
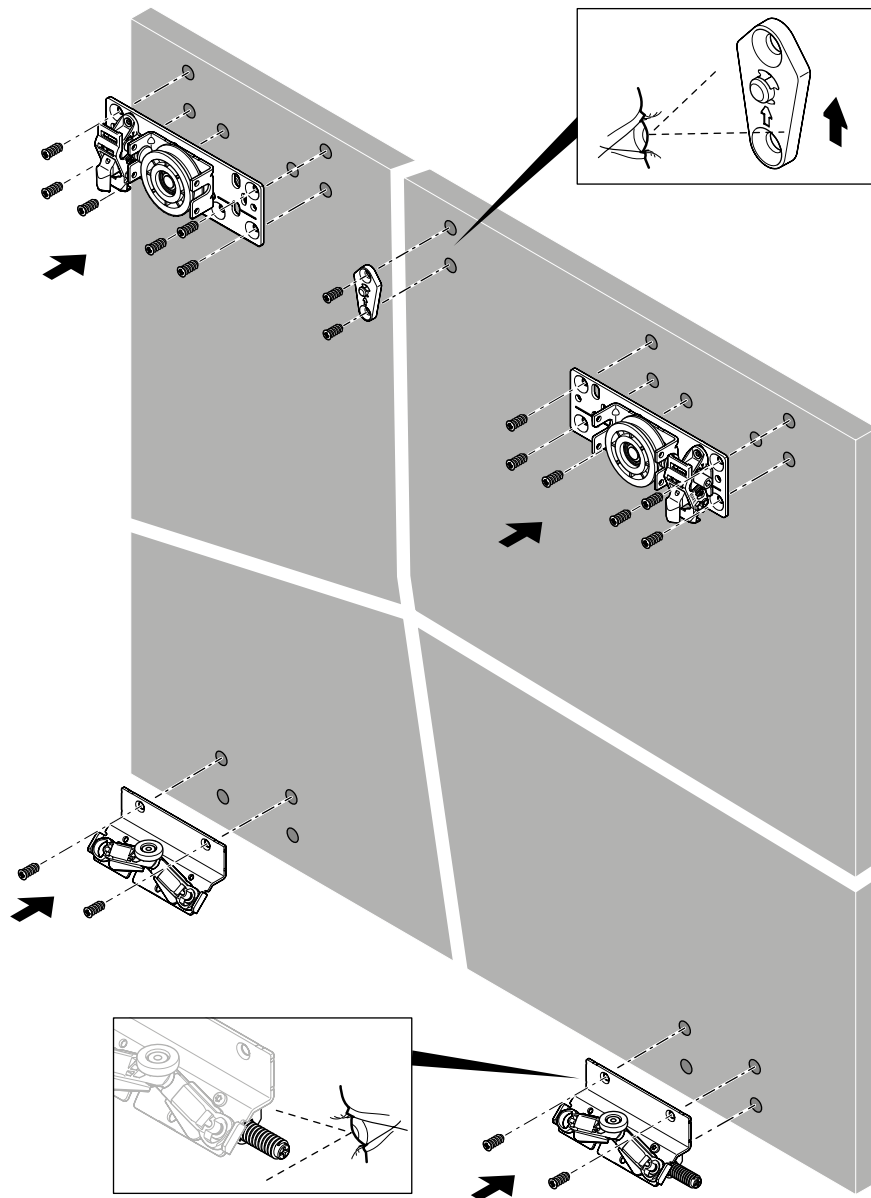
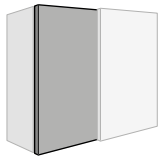

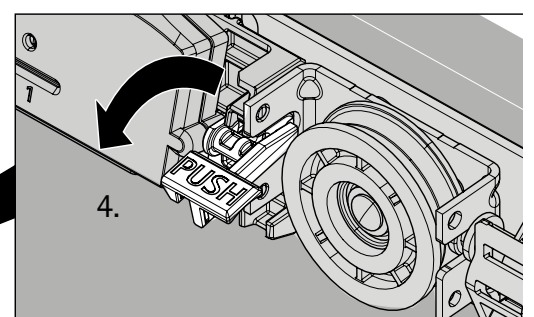
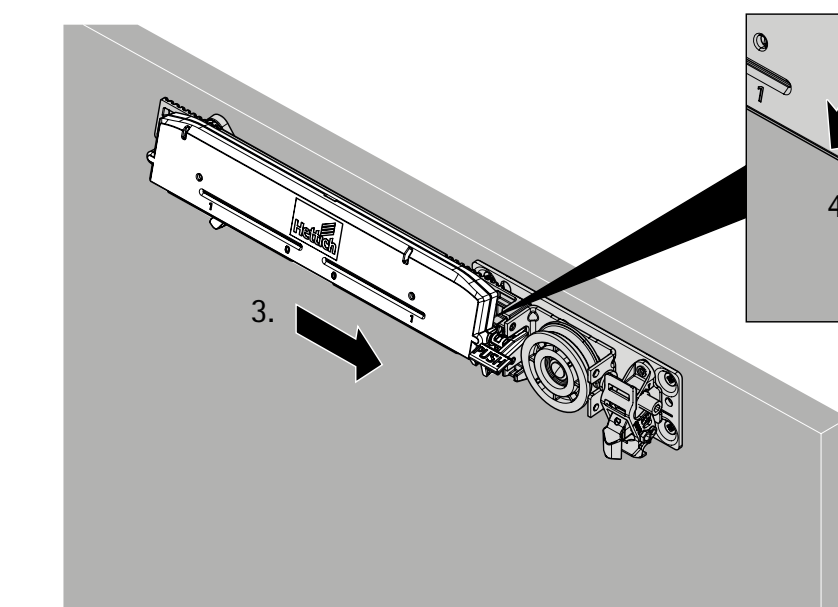
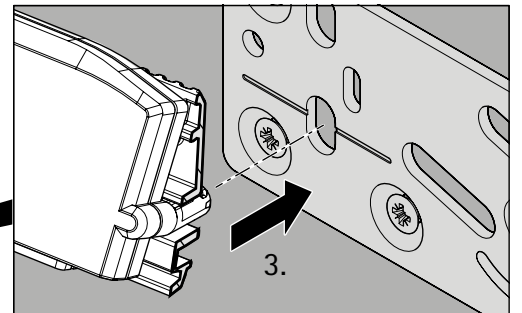
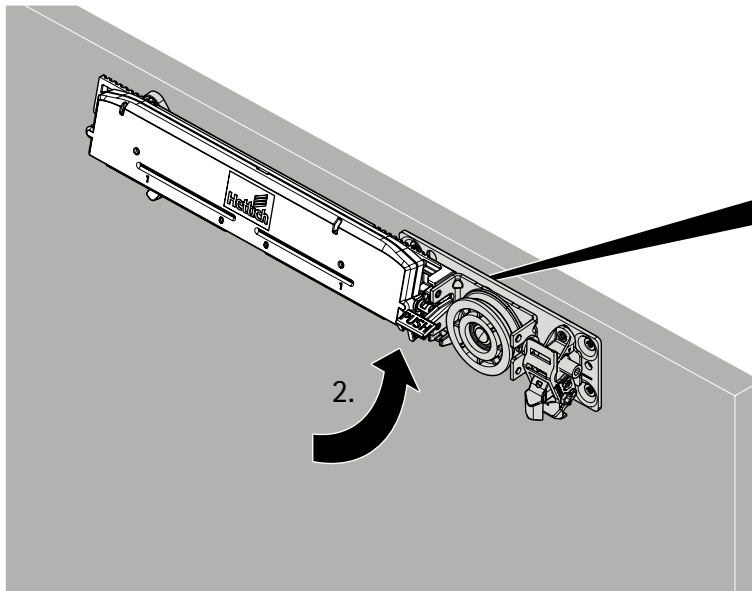
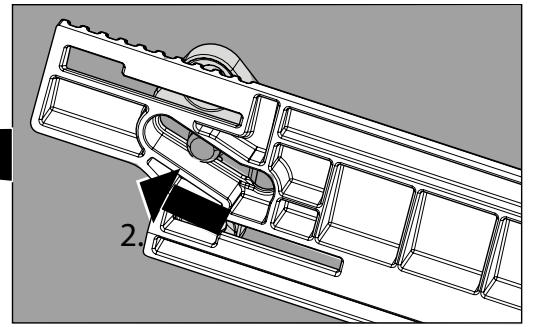
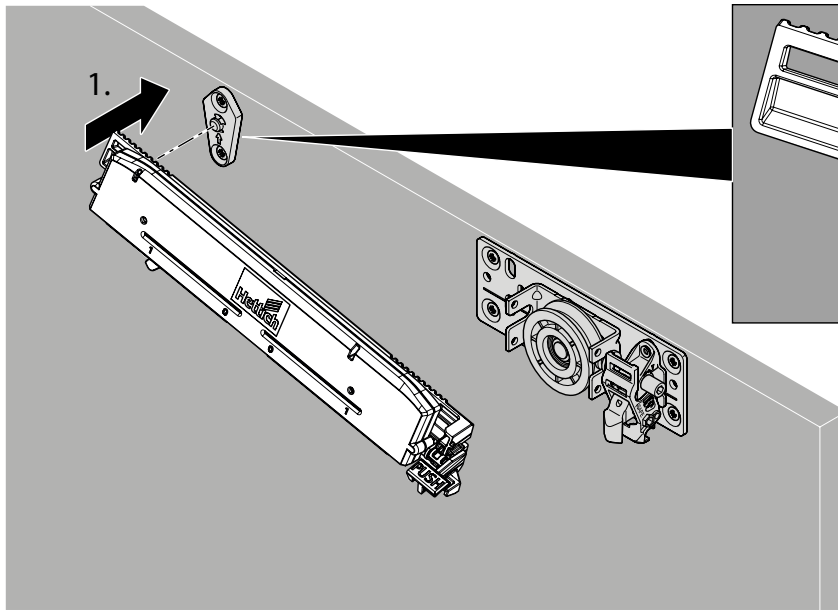
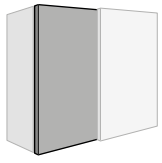

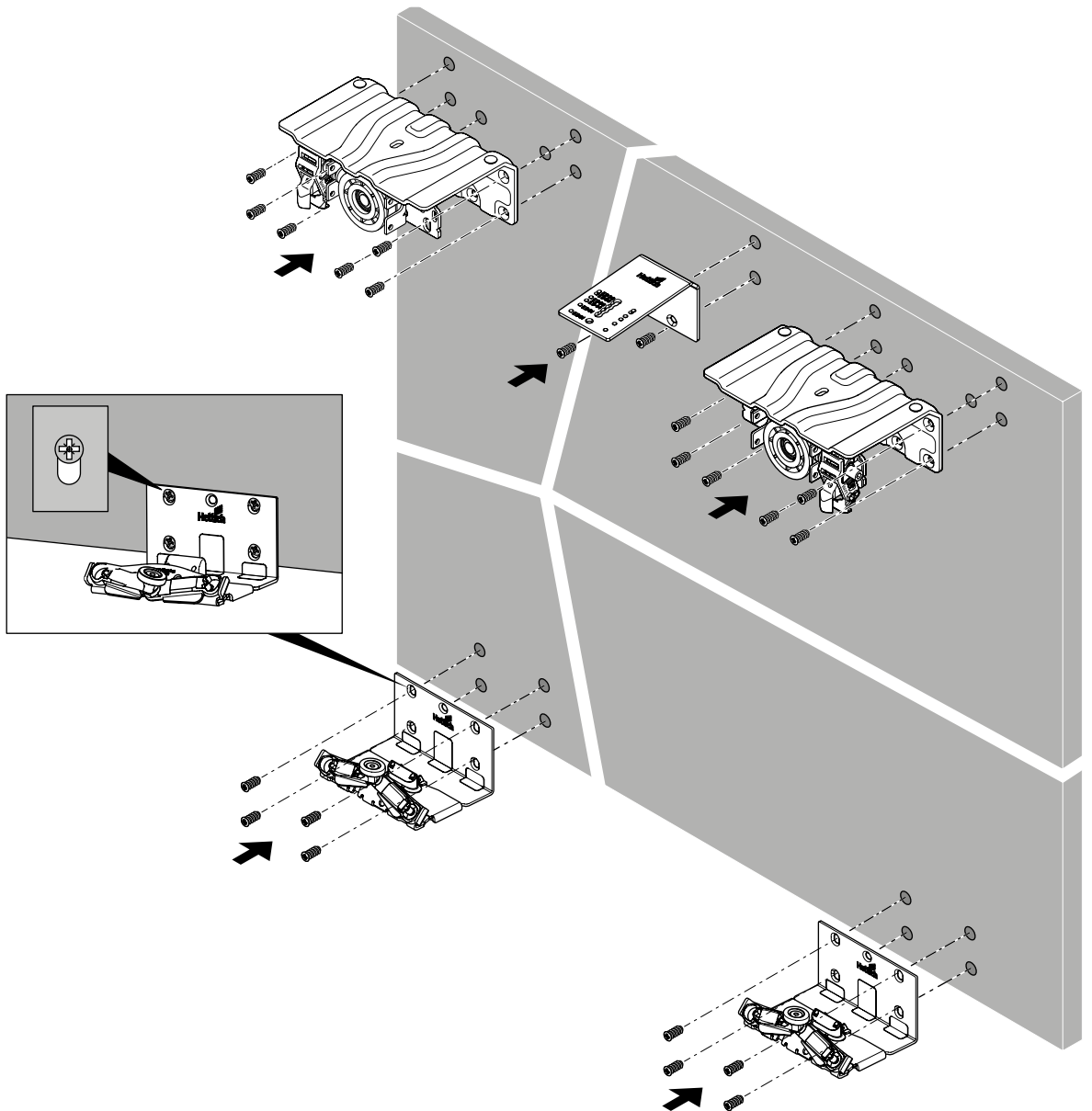
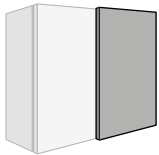
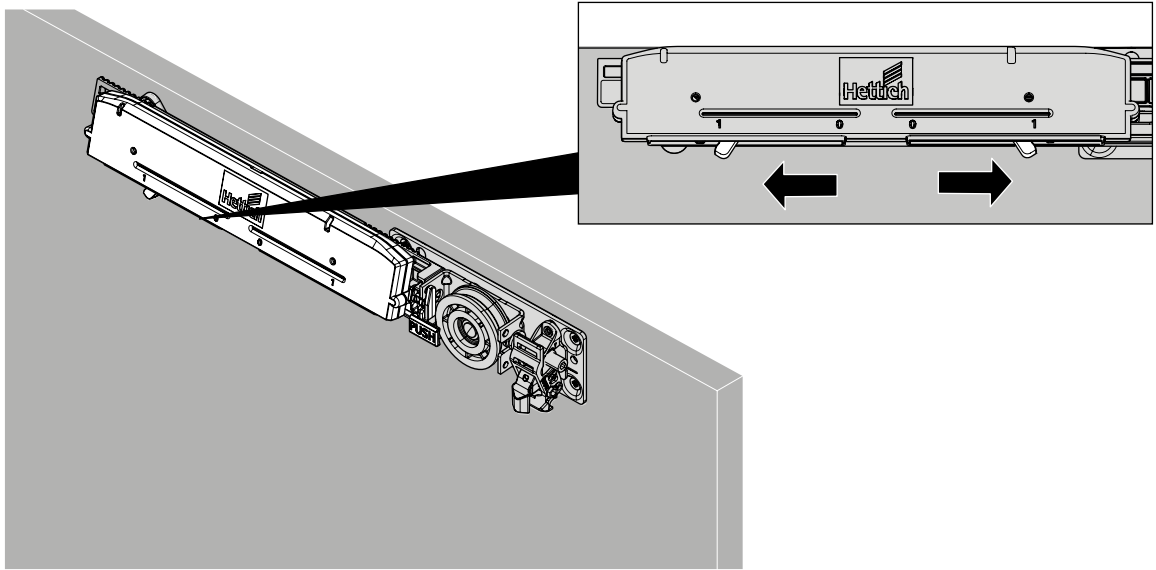

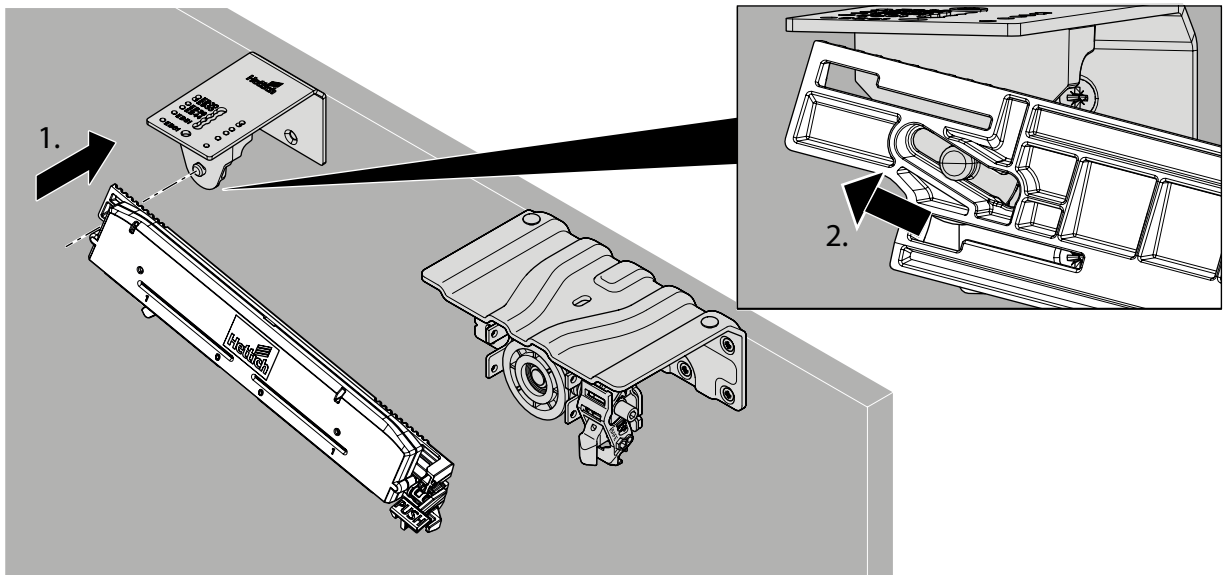
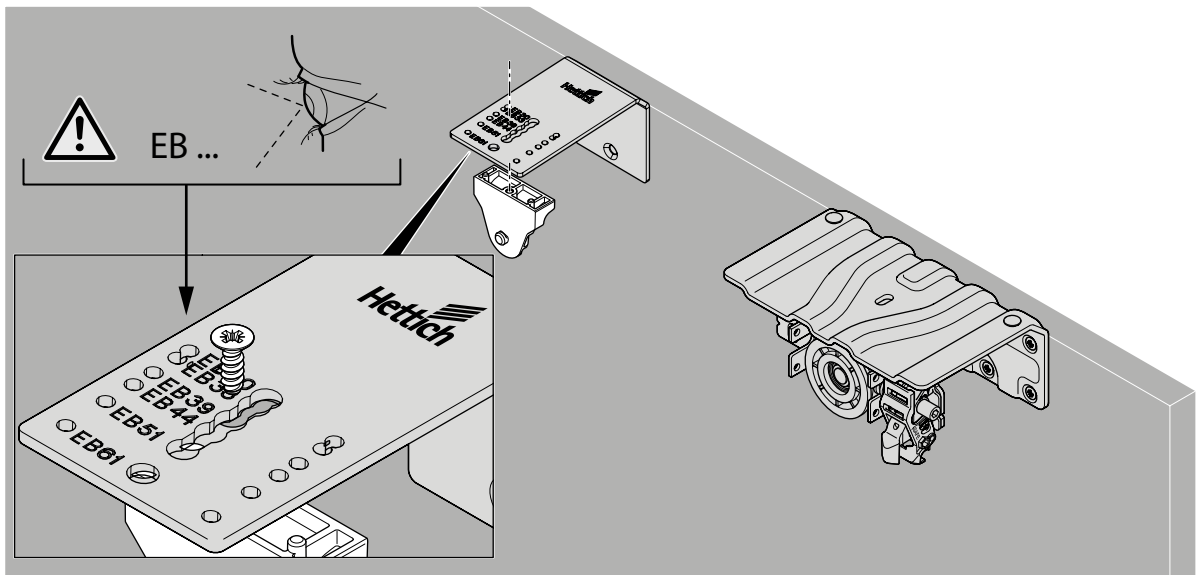
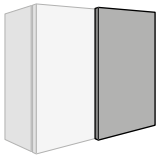
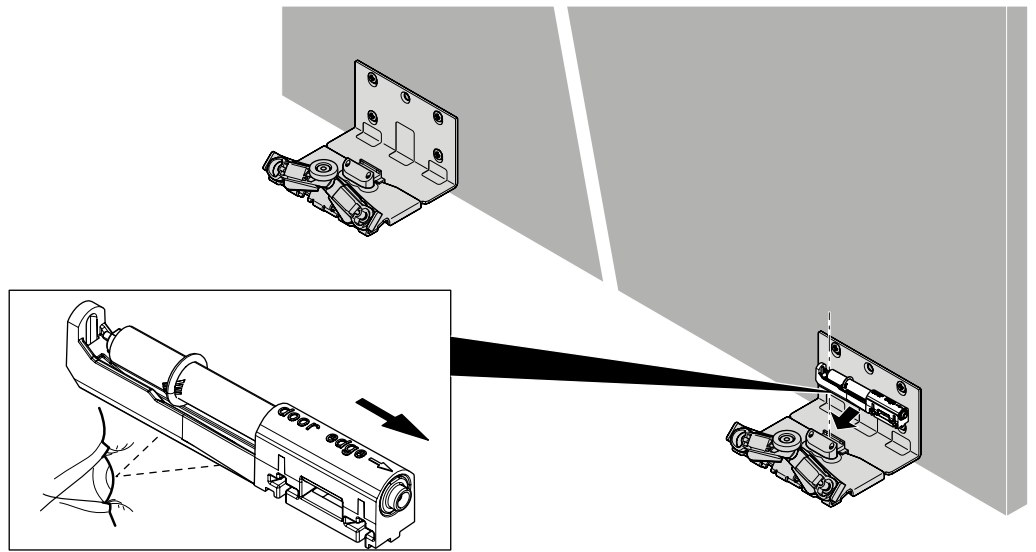

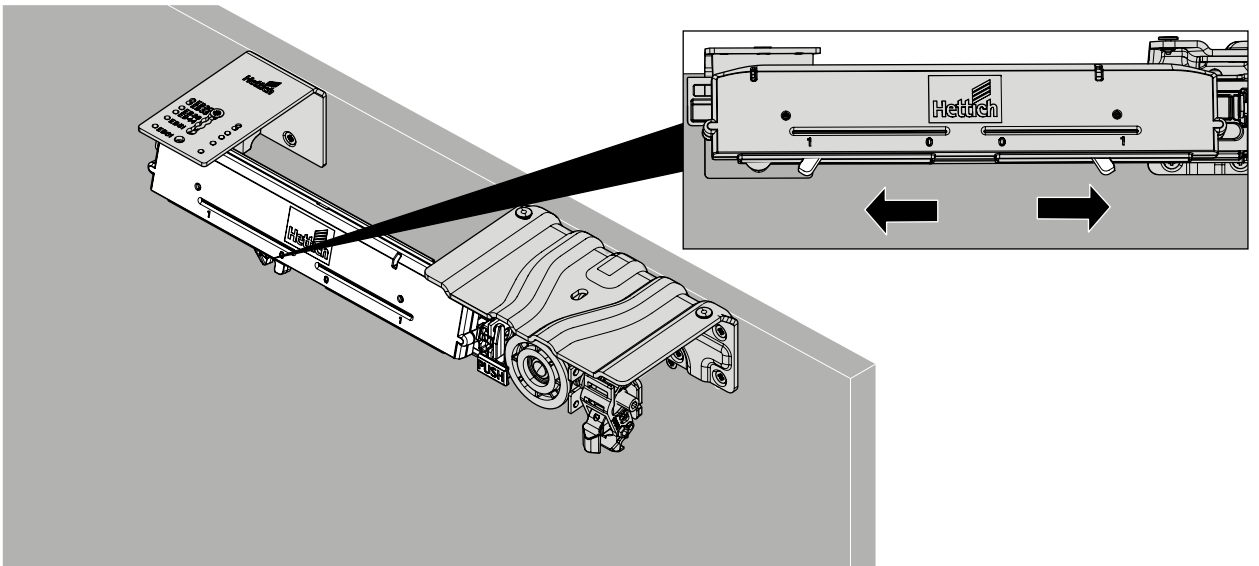
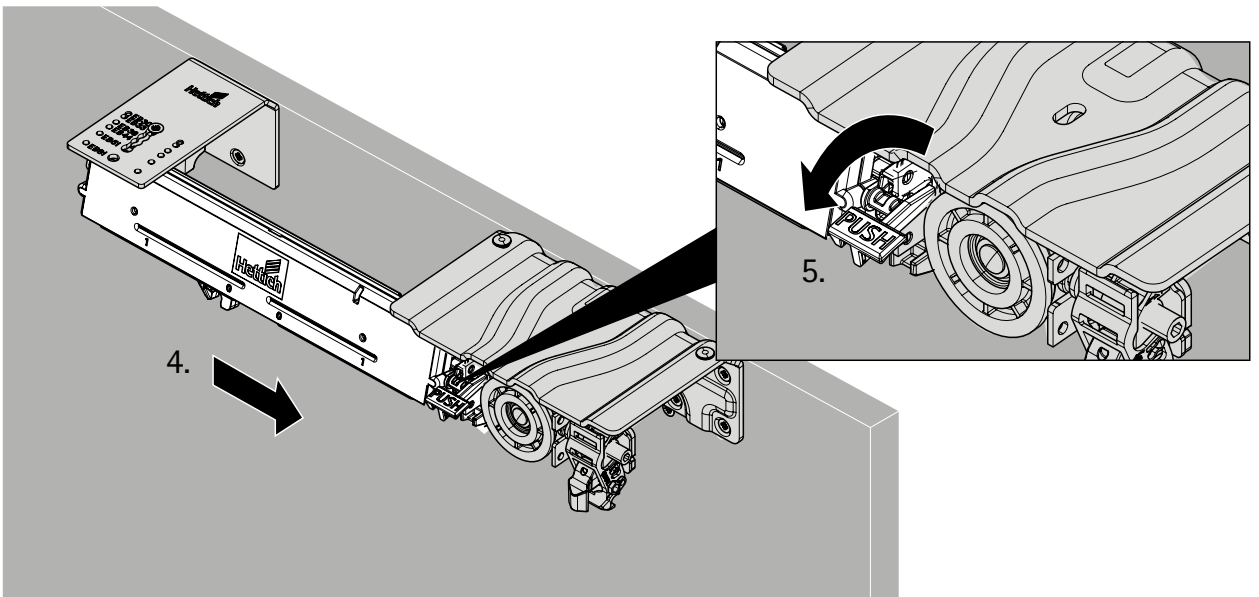
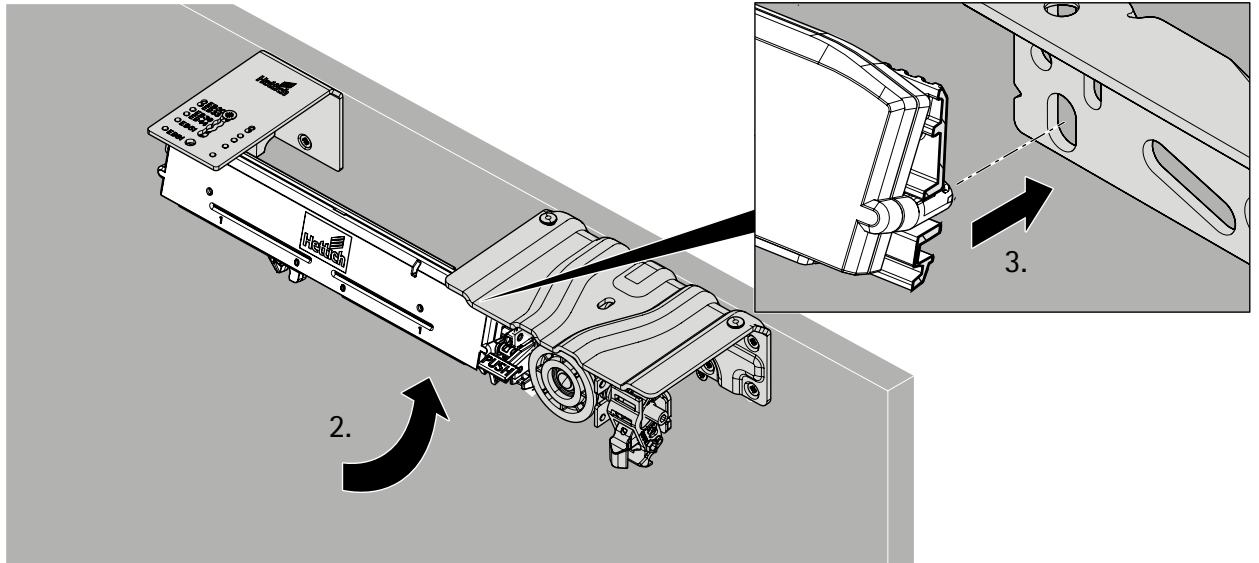



$L = TB - 5mm$

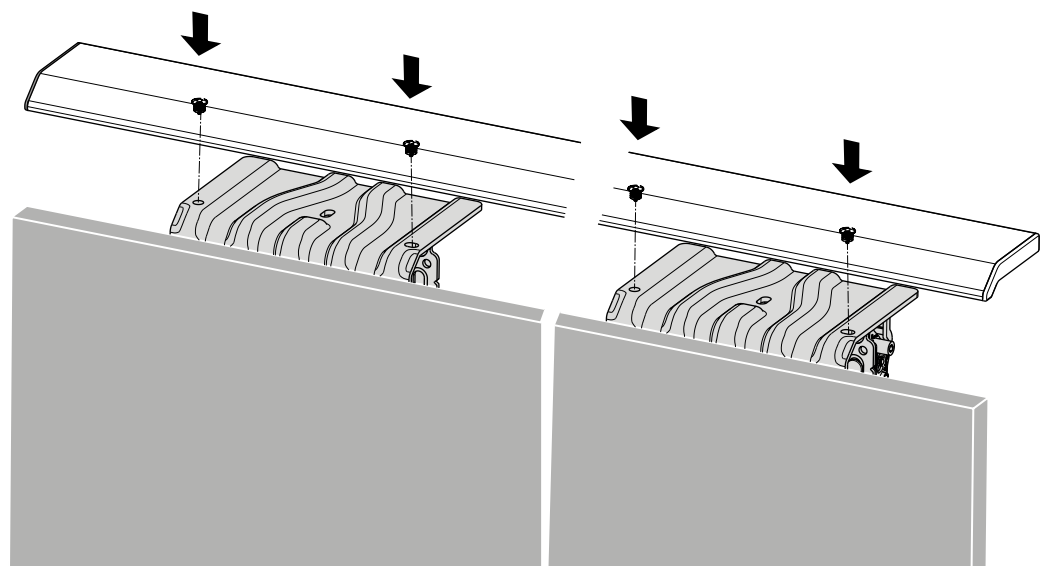
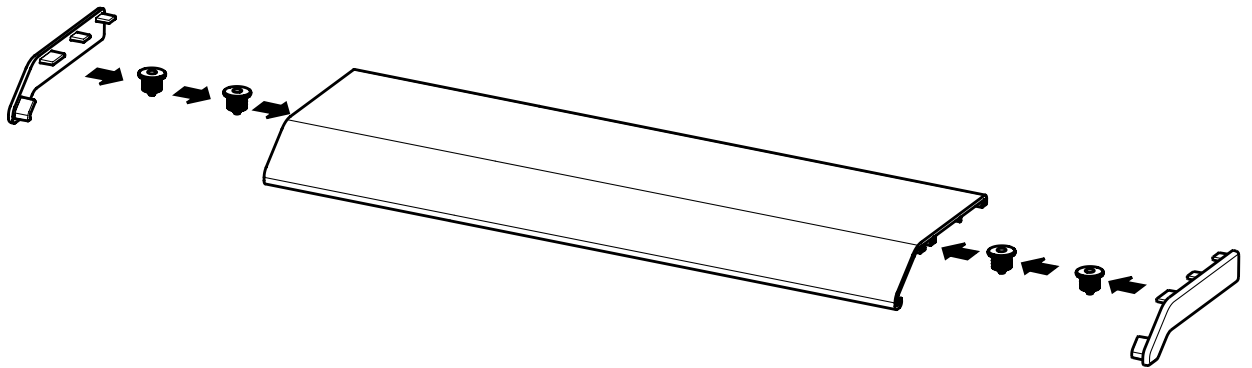
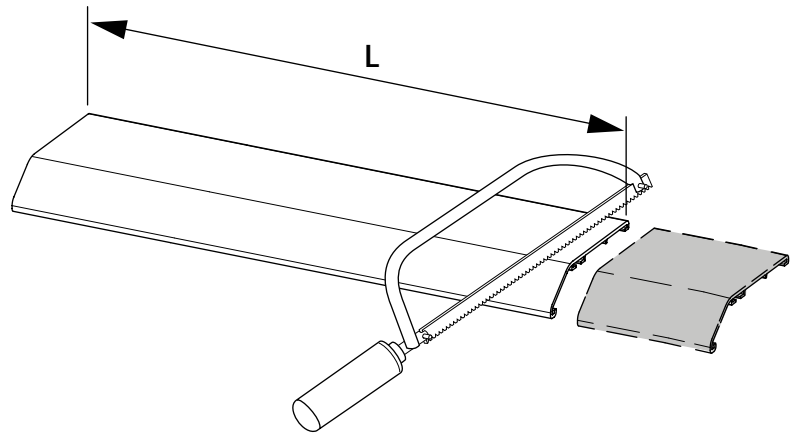
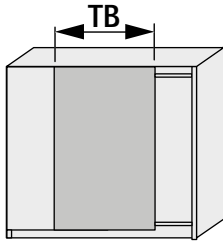

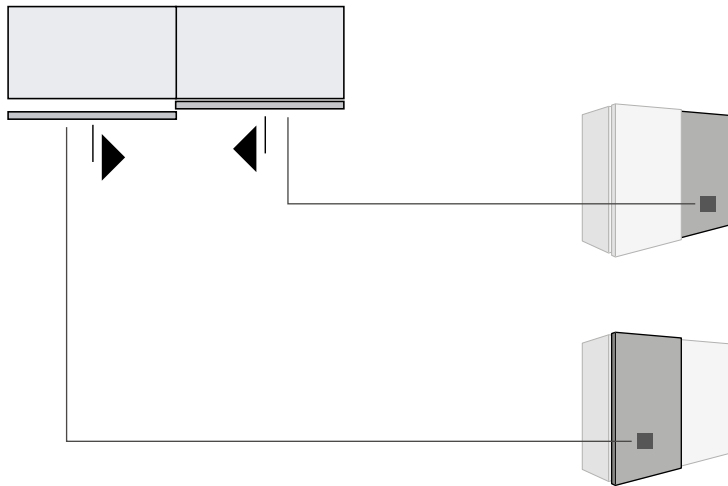

Silent System

