

InLine XL

(D) Montageanleitung

Obenlaufendes flächenbündiges Schiebetürsystem

(CZ) Montážní návod

Systém pro posuvné dveře v jedné rovině s horním nosným profilem

(DK) Monteringsvejledning

Skydelågesystem, der kører foroven og flugter med overfladen

(E) Instrucciones de montaje

Sistema de puerta corredera enrasada con deslizamiento superior

(F) Instructions de montage

Système de portes à fleur coulissant par le haut

(FI) Asennusohje

Ylhäällä kulkeva liukuovijärjestelmä, pinnat samassa tasossa

(GB) Installation instructions

Top running flush fitted sliding door system

(I) Istruzioni di montaggio

Sistema per ante scorrevoli a filo su binario superiore

(NL) Montagehandleiding

Bovenaan lopend vlak afsluitend schuifdeursysteem

(PL) Instrukcja montażu

System do drzwi przesuwanych z górnym mechanizmem jezdnym, z drzwiami tworzącymi po zamknięciu jedną płaszczyznę

(RU) Инструкция по монтажу

Система фурнитуры с верхним ходовым профилем для раздвижных компланарных дверей

(SE) Monteringsanvisning

Topplöpande plant skjutdörrssystem

(TR) Montaj kılavuzu

Üstte çalışan tek düzlem sürgü kapak sistemi

(KR) 설치 설명서

상부 러닝, 단차없이 설치되는 슬라이딩 도어 시스템

(JP) 金具取付けマニュアル

扉を完全に重なる位置まで全開できる引き戸金具

Technik für Möbel

Hettich



9 148 180
9 148 201
9 148 202
9 148 203
9 148 204
9 148 205
9 148 206
9 116 581
9 155 574
9 155 575



9 148 547
9 148 562

| | | 2 - 7 |
|--|--|---------|
| | | 8 - 9 |
| | | 10 - 11 |
| | | 12 - 13 |
| | | 15 |
| | | 16 - 17 |
| | | 18 - 20 |
| | | 21 - 27 |
| | | 28 |



(D) Bestimmungsgemäße Verwendung

Der Möbelbeschlag InLine XL wird für obenlaufende flächenbündige Schiebetürsysteme verwendet.

Er ist für die Verwendung in Möbeln nach EN 14749 und den Einsatz in geschützten, trockenen Innenräumen vorgesehen.

Eine andere als die unter „Bestimmungsgemäße Verwendung“ festgelegte Verwendung gilt als nicht bestimmungsgemäß.

Der Beschlag ist getestet nach EN 15706, Level 3.

Es wird empfohlen, den Schrank gegen Kippen zu sichern.

(CZ) Použití v souladu s určením

Nábytkové kování InLine XL se používá pro systémy posuvných dveří v jedné rovině a s horním nosným profilem.

Je určeno do nábytku podle EN 14749 a pro použití v chráněných a suchých interiérech.

Jiné použití, než které je definované pod bodem „Použití v souladu s určením“, se považuje za nesprávné.

Kování je testováno podle EN 15706, úroveň 3.

Doporučuje se zajistit skříň proti překlopení.

(DK) Tilsigtet brug

Møbelbeslaget InLine XL anvendes til skydelågesystemer, der kører foroven og flugter med overfladen.

Det er beregnet til anvendelse i møbler i overensstemmelse med EN 14749 og til brug i beskyttede, tørre indendørs lokaler.

Anden brug end den, der er fastlagt under „Tilsigtet brug“, betragtes som utilsigtet brug.

Beslaget er testet iht. EN 15706, level 3.

Det anbefales at sikre skabet mod at vælte.

(E) Utilización conforme al uso previsto

El herraje de mueble InLine XL se utiliza para el sistema de puerta corredera enrasada con deslizamiento superior.

Está previsto para el uso en muebles según EN 14749 y su aplicación en estancias protegidas y secas.

Cualquier otra utilización que difiera de la „Utilización conforme al uso previsto“ se considera no conforme a lo previsto.

El herraje ha sido verificado conforme a EN 15706, nivel 3.

Se recomienda asegurar el armario para evitar que pueda volcar.

(F) Utilisation conforme à la destination prévue

La ferrure de meuble InLine XL est utilisée pour les systèmes de portes à fleur coulissant par le haut.

Elle est prévue pour une utilisation dans des meubles conformément à la norme EN 14749 et, à l'intérieur, dans des pièces non humides et protégées.

Toute utilisation autre que celle indiquée dans l'« utilisation conforme à la destination prévue » est considérée non-conforme.

La ferrure est testée selon la norme EN15706, niveau 3.

Il est conseillé de sécuriser l'armoire pour éviter qu'elle ne bascule.

(FI) Käyttötarkoitus

Huonekaluhelaa InLine XL käytetään ylhäällä kulkevilla liukuovijärjestelmissä, joiden pinnat ovat samassa tasossa.

Se on tarkoitettu käytettäväksi huonekaluissa EN 14749 -standardin mukaisesti ja sitä voidaan käyttää suojaissa, kuivissa sisätiloissa.

Kaikenlainen muu kuin „käyttötarkoituksen mukainen“ käyttö ei ole käyttötarkoituksen mukaista käyttöä.

Hela on testattu EN 15706 -standardin, taso 3, mukaisesti.

Kaappi kannattaa varmistaa kaatumista vastaan.

(GB) Intended Use

The InLine XL furniture fitting is used for top running flush fitted sliding door systems.

It is intended for application in furniture to EN14749 and use in dry indoor environments where it is protected from the elements.

Any use other than that defined under „Intended Use“ will be deemed to be non-intended use.

The fitting is tested to EN 15706, Level 3.

It is recommended to prevent the cabinet from toppling over.

(I) Uso conforme alla destinazione

Il dispositivo InLine XL viene impiegato nel montaggio dei sistemi per ante scorrevoli a filo su binario superiore e il suo uso è previsto in mobili conformi alla norma EN 14749 in ambienti interni protetti e asciutti.

Ogni altro utilizzo diverso da quanto indicato al punto "Uso conforme alla destinazione" viene considerato non conforme.

Il sistema è testato secondo la EN 15706, Level 3.

Si consiglia di fissare il mobile per evitare che si ribalti.

(NL) Doelmatig gebruik

Het meubelbeslag InLine XL wordt voor bovenaan lopende, vlak afsluitende schuifdeursystemen gebruikt.
 Het is gemaakt voor gebruik in meubels volgens EN 14749 en toepassing in beschutte, droge binnenruimtes.
 Elk ander gebruik dan vastgelegd onder 'Doelmatig gebruik' geldt als zijnde niet volgens de voorschriften.
 Het beslag werd getest volgens EN 15706, level 3.
 Wij adviseren de kast te beveiligen tegen kantelen.

(PL) Zastosowanie zgodne z przeznaczeniem

Okucie meblowe InLine XL stosowane jest w systemach do drzwi przesuwanych, tworzących po zamknięciu jedną płaszczyznę, z górnym mechanizmem jezdnym.
 Przeznaczone jest do zastosowania w meblach zgodnie z EN 14749 oraz do zastosowania w osłoniętych, suchych pomieszczeniach wewnętrznych.
 Zastosowanie inne niż określone jako „Zastosowanie zgodne z przeznaczeniem” jest niezgodne z przeznaczeniem.
 Okucie zostało przetestowane zgodnie z EN 15706, poziom 3.
 Zaleca się zabezpieczenie szafy przed przewróceniem się.

(RU) Использование по назначению

Мебельная фурнитура InLine XL с верхним ходовым профилем предназначена для изготовления шкафов с раздвижными дверьми, фасады которых в закрытом положении находятся в одной плоскости.
 Она предусмотрена для использования в мебели по стандарту EN 14749 и для применения в защищенных, сухих внутренних помещениях.
 Иное применение, кроме указанного в разделе „Использование по назначению”, считается использованием не по назначению.
 Фурнитура испытана по стандарту EN 15706, уровень 3.
 Рекомендуется принять меры против опрокидывания шкафа.

(SE) Ändamålsenlig användning

Möbelbeslaget InLine XL används för toplöplande plana skjutdörrssystem.
 Det är tillverkat för att användas i möbler enligt EN 14749, i skyddade, torra utrymmen inomhus.
 En annan användning än den som fastställts med „Ändamålsenlig användning”, anses som icke ändamålsenlig.
 Beslaget är testat enligt EN 15706, nivå 3.
 Det rekommenderas att säkra skåpet mot att välta.

(TR) Amacına uygun kullanım

Mobilya aksesuarı InLine XL, üstte çalışan tek düzlem sürgü kapak sistemleri için kullanılmaktadır.
 EN 14749 standardına uygun, kuru ve korunaklı iç mekan mobilyalarında kullanım için öngörülmüştür.
 „Amacına uygun kullanım” başlığı altında öngörülenin dışındaki bir kullanım, amacına aykırı olarak nitelendirilir.
 Aksesuar, EN 15706, Seviye 3 uyarınca test edilmiştir.
 Dolabın, devrilmeye karşı emniyete alınması önerilir.

(KR) 사용용도

InLine XL은 상부 러닝방식의 단차없이 설치되는 슬라이딩 도어 시스템입니다.
 EN14749에 따라 인증된 가구용 피팅으로서 손상을 방지하기 위해 건조한 실내에서 사용해야 합니다.
 제시된 목적 이외의 용도에는 사용할 수 없습니다.
 이 피팅은 EN 15706, Level 3에 따라 테스트 완료 하였습니다.
 설치시 수납장을 넘어뜨리지 않도록 유의하시기 바랍니다.

(JP) 用途

インラインXLは扉を完全に重なる位置まで全開できる大型家具用引き戸金具で、扉は上部レールで支える吊り戸タイプです。
 通常の屋内（異常な高湿度及び温度ではない環境）に設置される家具以外での使用には適しません。
 この金具はヨーロッパ品質基準EN 15706のレベル3の試験をパスしています。
 家具本体は転倒せぬよう必ず建築躯体に固定してください。



www.hettich.com/short/ecae79



www.hettich.com/short/624526

Kurzanleitung zur Montage (Video als Download)
Krátký návod k montáži (video ke stažení)
Kort vejledning i montering (video til download)
Guía de montaje (video para descargar)
Instructions de montage succinctes (vidéo à télécharger)
Asennuksen pikaohje (ladattava video)
Short installation guide (video for downloading)
Istruzioni di montaggio (Video disponibile per il download)

Erweiterte Montageanleitung als Download
 Sie benötigen eine ausführlichere Montageanleitung? Kein Problem! Wir haben zusätzliche Tipps und Informationen in Ihrer Sprache zusammengestellt, um Ihnen die Montage zu erleichtern. Hier können Sie die erweiterte Anleitung herunterladen.

Rozšířený montážní návod ke stažení
 Potřebujete podrobnější montážní návod? Žádný problém! Jsou k dispozici další informace a doporučení pro usnadnění montáže. Rozšířený návod můžete stáhnout zde.

Udvidet monteringsvejledning som download
 Har du brug for en mere udførlig monteringsvejledning? Det er ikke noget problem! Vi har samlet ekstra tips og oplysninger på dit sprog for at gøre monteringen lettere for dig. Her kan du downloade den udvidede vejledning.

Instrucciones de montaje ampliadas disponibles para su descarga
 ¿Necesita unas instrucciones de montaje detalladas? ¡Ningún problema! Hemos recopilado información y consejos complementarios en su idioma para facilitarle el montaje. Aquí puede descargar las instrucciones ampliadas.

Instructions de montage approfondies à télécharger
 Avez-vous besoin d'instructions de montage plus approfondies? Pas de problème! Nous avons réuni des astuces et des informations supplémentaires dans votre langue pour vous faciliter le montage. Vous pouvez télécharger ici les instructions approfondies.

Detailed installation instructions for downloading
 Do you need installation instructions of a more detailed nature? Not a problem. We have put together some additional advice and information in English that will make installation easier for you. The more detailed instructions are available for downloading here.

Gelişmiş montaj talimatı
 Detaylı montaj talimatına mı ihtiyacınız var? Problem değil! Montajınızı kolaylaştırmak için anadilinizde, birçok faydalı öneri ve bilgiyi bir araya topladık. Buradan gelişmiş montaj talimatını indirebilirsiniz.

Korte handleiding voor de montage (video om te downloaden)
Skrócona instrukcja montażu (film do pobrania)
Краткая инструкция по монтажу (видео, доступное для загрузки)
Kort anvisning för monteringen (video att ladda ner)
Montaj için kısa talimat (indirilebilir video)
간단한 설치 가이드 (설치 비디오 다운로드)

Download istruzioni di montaggio ampliate
 Vi servono istruzioni di montaggio più dettagliate? Nessun problema! Abbiamo raccolto ulteriori consigli e informazioni nella vostra lingua per facilitarvi le operazioni di montaggio. Qui potete scaricare le versioni ampliate delle istruzioni.

Utförlig monteringsanvisning att ladda ner
 Behöver du en utförlig monteringsanvisning? Inget problem! Vi har samlat ihop extra tips och information på ditt eget språk för att underlätta monteringen. Här kan du ladda ner anvisningen.

Uitgebreide montagehandleiding on te downloaden
 U heeft een uitgebreidere montagehandleiding nodig? Geen probleem! Wij hebben bijkomende tips en informatie in uw taal samengesteld om de montage makkelijker te maken. Hier kan u de uitgebreide handleiding downloaden.

Rozszerzona instrukcja montażu w formie pliku do pobrania
 Potrzebujecie Państwo jeszcze bardziej szczegółowej instrukcji montażu? To żaden problem! Przygotowaliśmy w Państwa języku dodatkowe wskazówki i informacje, które ułatwią Państwu montaż. Tutaj możecie Państwo pobrać rozszerzoną instrukcję.

Расширенная инструкция по монтажу для скачивания
 Вам нужна расширенная инструкция по монтажу? Нет ничего проще! Мы собрали дополнительные рекомендации и информацию на вашем языке, чтобы облегчить вам монтаж. Здесь вы можете загрузить расширенную инструкцию.

Ladattava laajennettu asennusohje
 Tarvitset seikkaperäisemmän asennusohjeen? Ei ongelma! Olemme kooneet suomeksi käännettyjä lisävinkkejä ja -tietoja, jotka helpottavat asennusta. Voit ladata laajennetun ohjeen tästä.

설치 설명서 다운로드
 자세한 설치 설명서가 필요하십니까? 문제 없습니다. 더욱 쉽게 설치할 수 있도록 한국어 설치 설명서가 준비되어 있습니다. 여기서 설치 설명서를 다운받을 수 있습니다.

より詳細な情報のダウンロード
 インラインXL引き戸金具のより詳しい説明が必要な場合は、ここからダウンロードしてください。

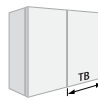
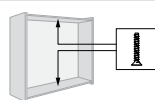

9 148 547
 TB = 750 - 1.199

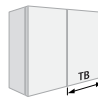
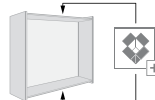

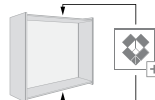

9 148 562
 TB = 1.200 - 2.000

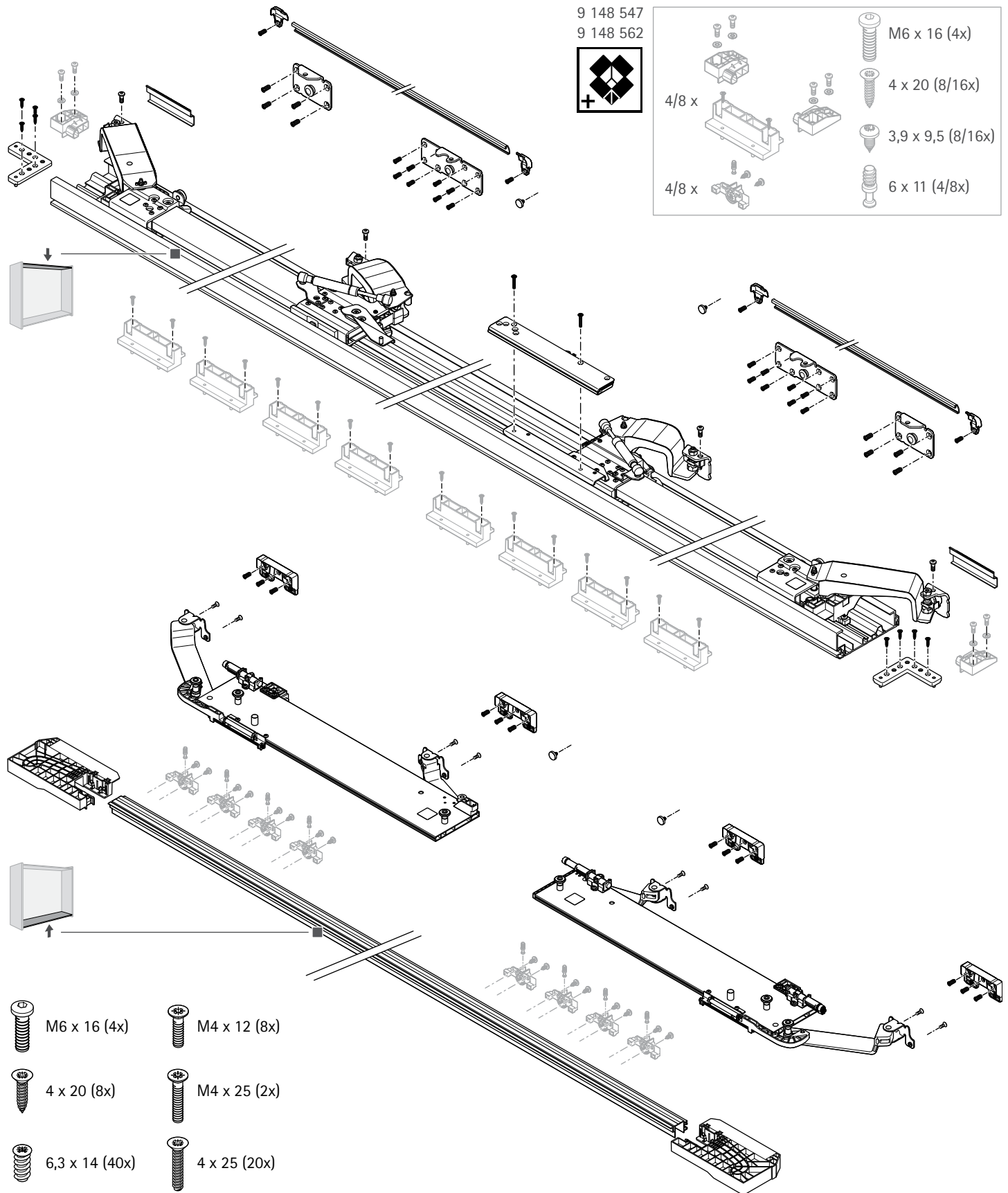

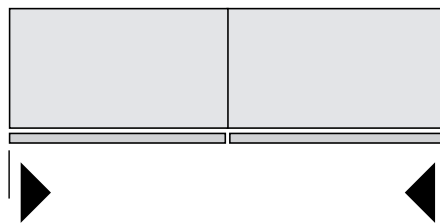
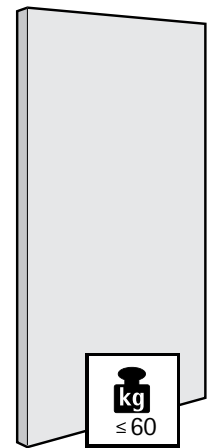
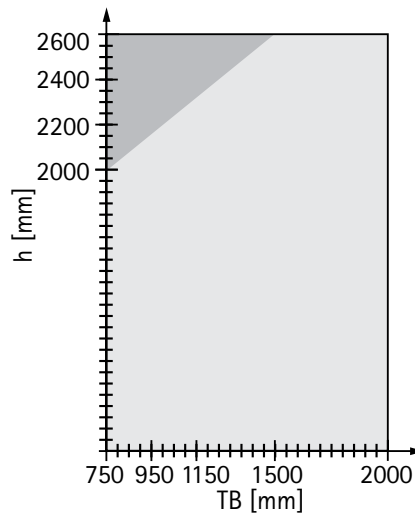
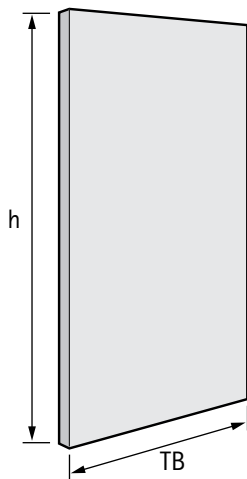
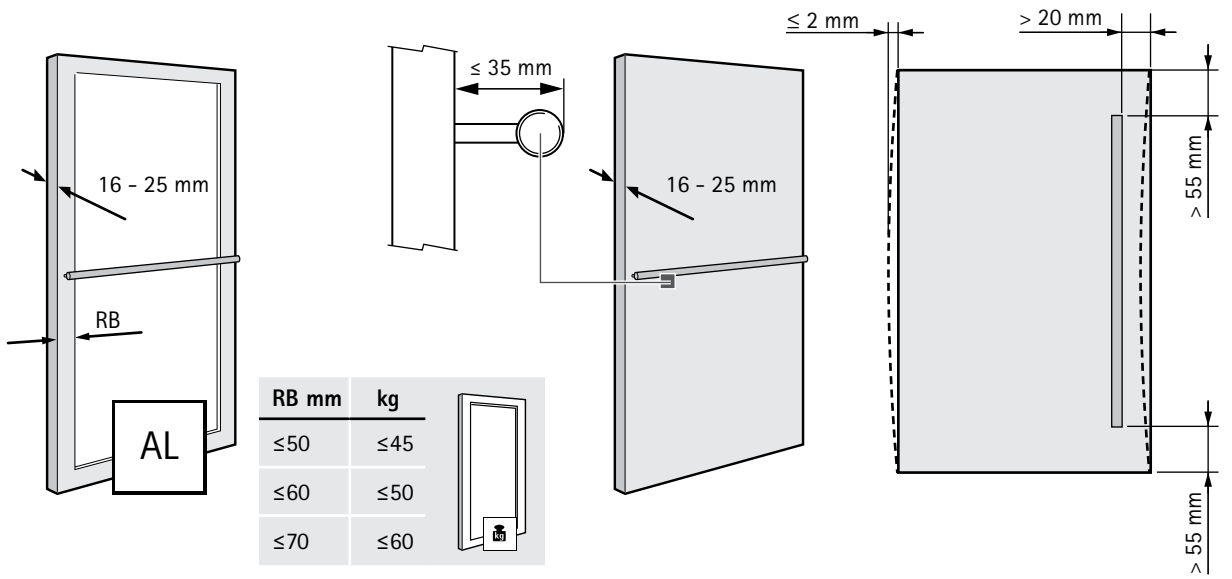

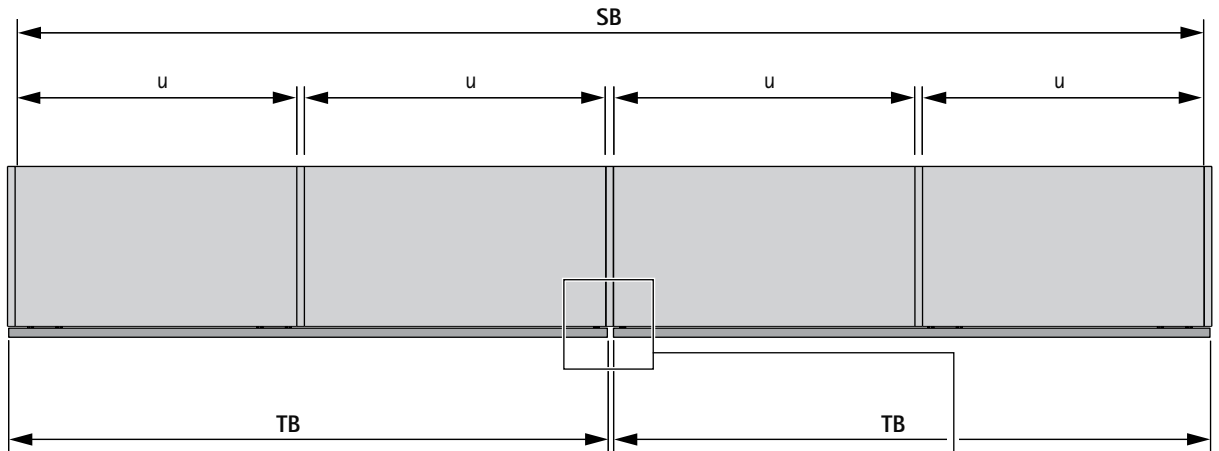



|  | kg | u (max) |
|--|----|---------|
| | 40 | 1200 |
| | 50 | 1000 |
| | 60 | 800 |

| D | F (min) |
|----|---------|
| 16 | 5 |
| 18 | 6 |
| 19 | 6 |
| 22 | 7 |
| 25 | 8 |

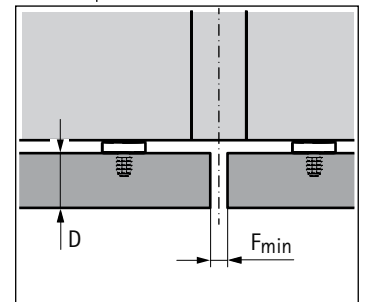

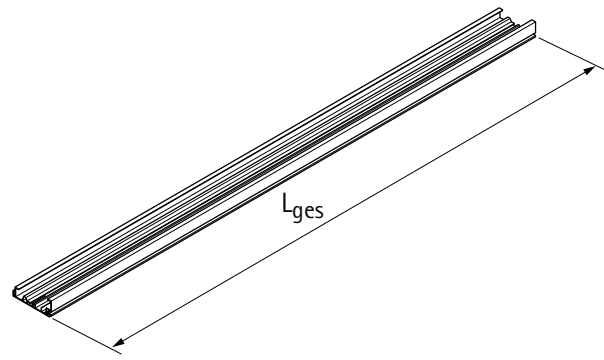
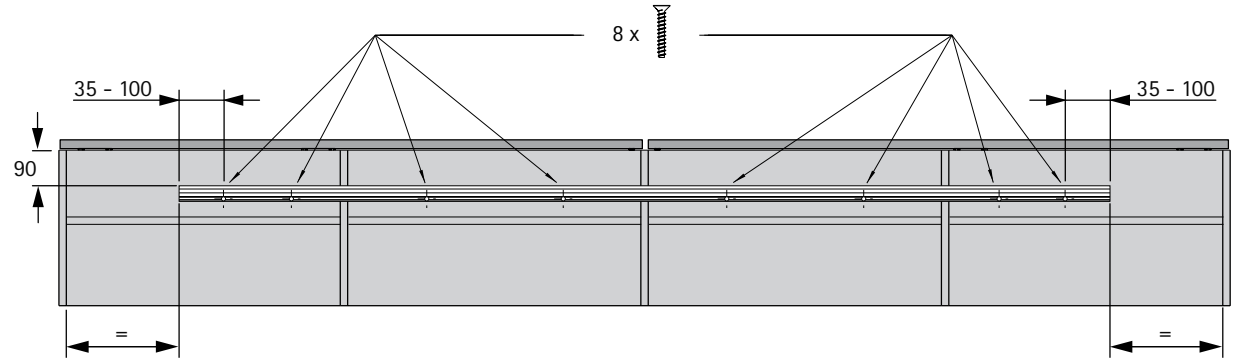
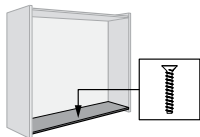
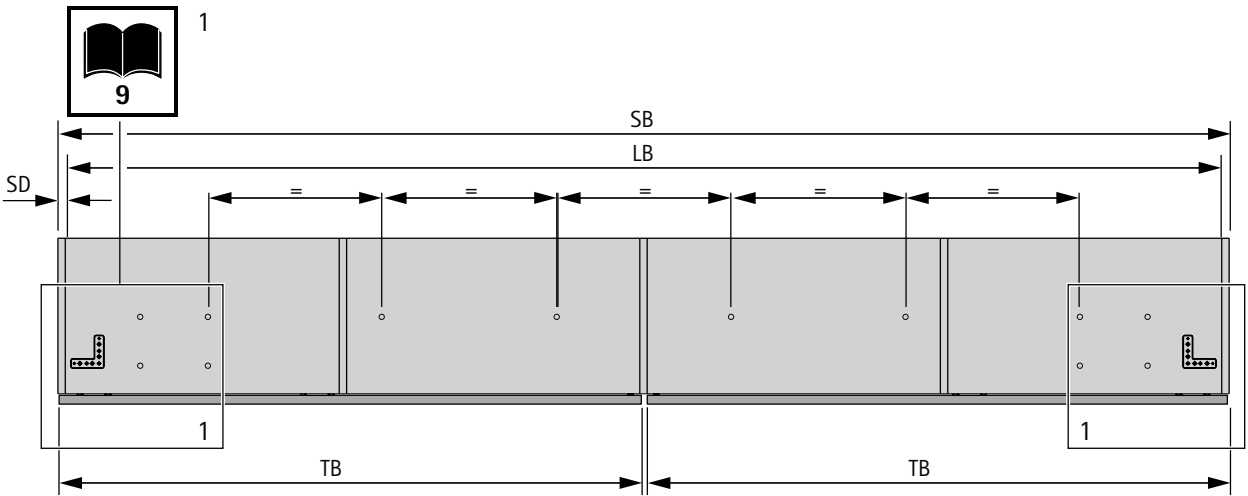
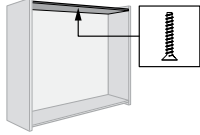

| TB | Lges | X | A (max) |
|-------------|------|-------|---------|
| 750 - 819 | 1294 | 215,5 | 13 |
| 820 - 909 | 1434 | 240,5 | 13 |
| 910 - 1044 | 1606 | 260,5 | 17 |
| 1045 - 1199 | 1876 | 310,5 | 17 |
| 1200 - 1299 | 2164 | 410,5 | 28 |
| 1300 - 1499 | 2364 | 410,5 | 28 |
| 1500 - 1599 | 2764 | 560,5 | 28 |
| 1600 - 1799 | 2964 | 560,5 | 28 |
| 1800 - 1899 | 3364 | 710,5 | 28 |
| 1900 - 2000 | 3564 | 710,5 | 28 |

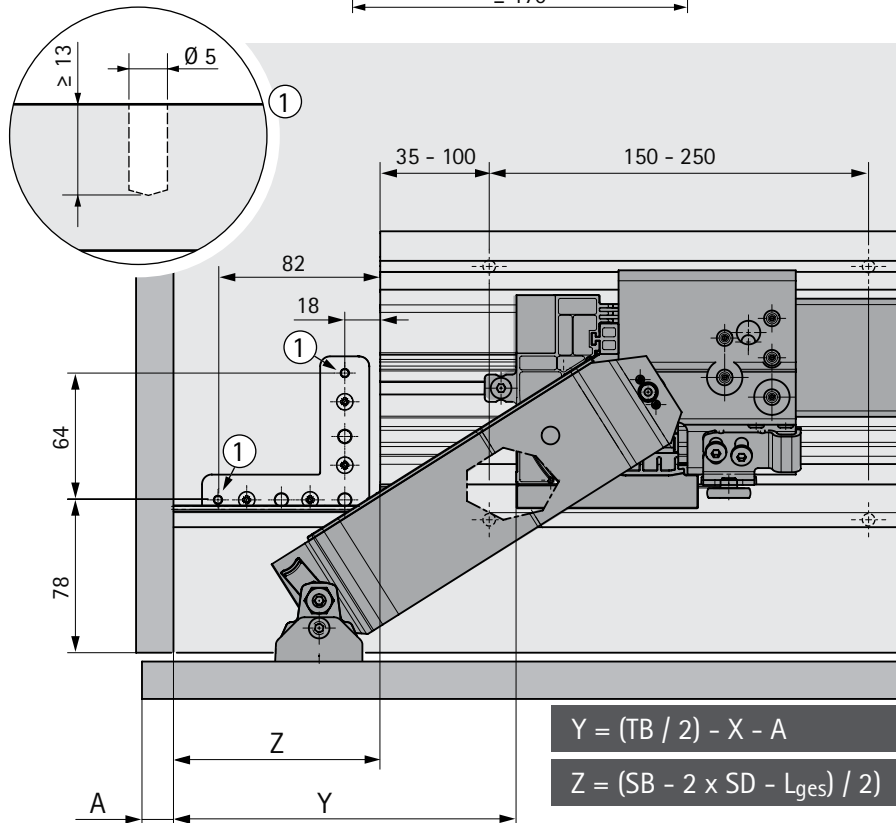
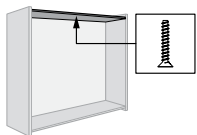
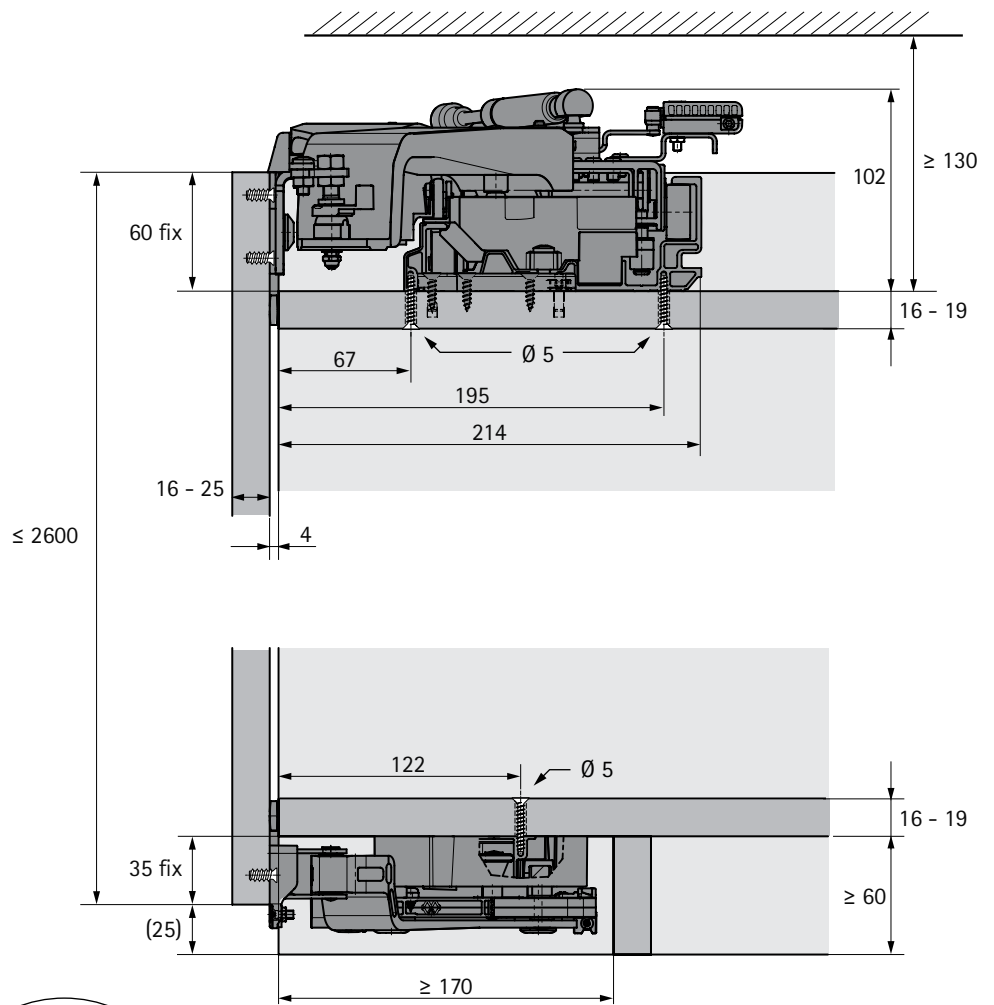

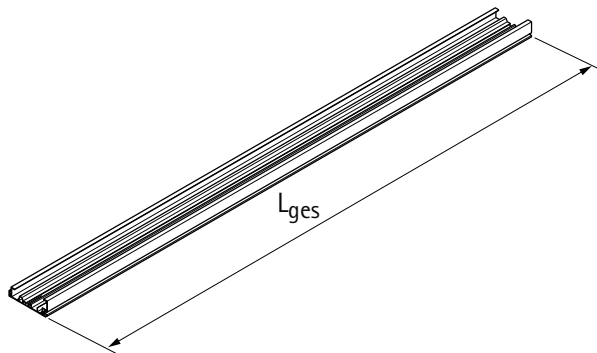
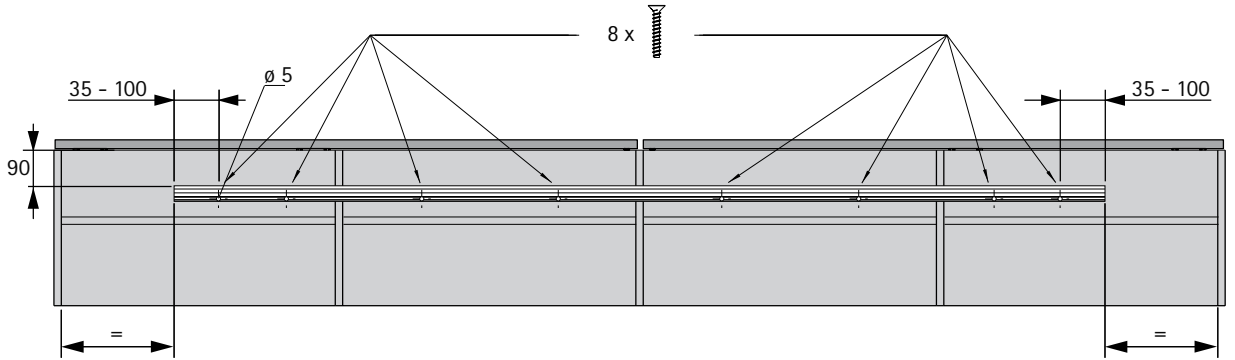
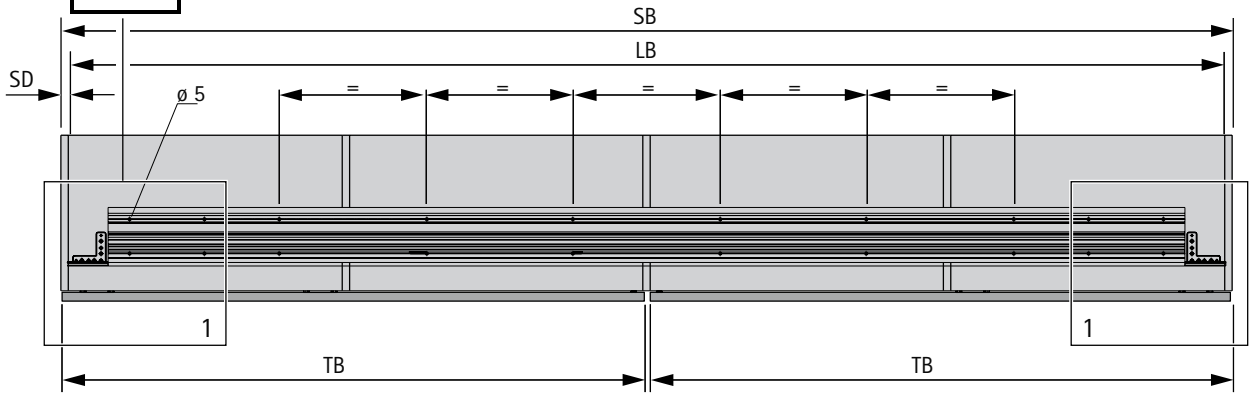

| TB | Lges | X | A (max) |
|-------------|------|-------|---------|
| 750 - 819 | 1294 | 215,5 | 13 |
| 820 - 909 | 1434 | 240,5 | 13 |
| 910 - 1044 | 1606 | 260,5 | 17 |
| 1045 - 1199 | 1876 | 310,5 | 17 |
| 1200 - 1299 | 2164 | 410,5 | 28 |
| 1300 - 1499 | 2364 | 410,5 | 28 |
| 1500 - 1599 | 2764 | 560,5 | 28 |
| 1600 - 1799 | 2964 | 560,5 | 28 |
| 1800 - 1899 | 3364 | 710,5 | 28 |
| 1900 - 2000 | 3564 | 710,5 | 28 |

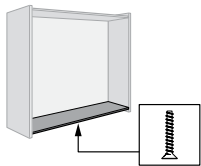
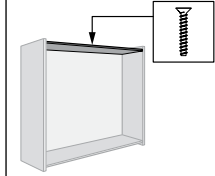

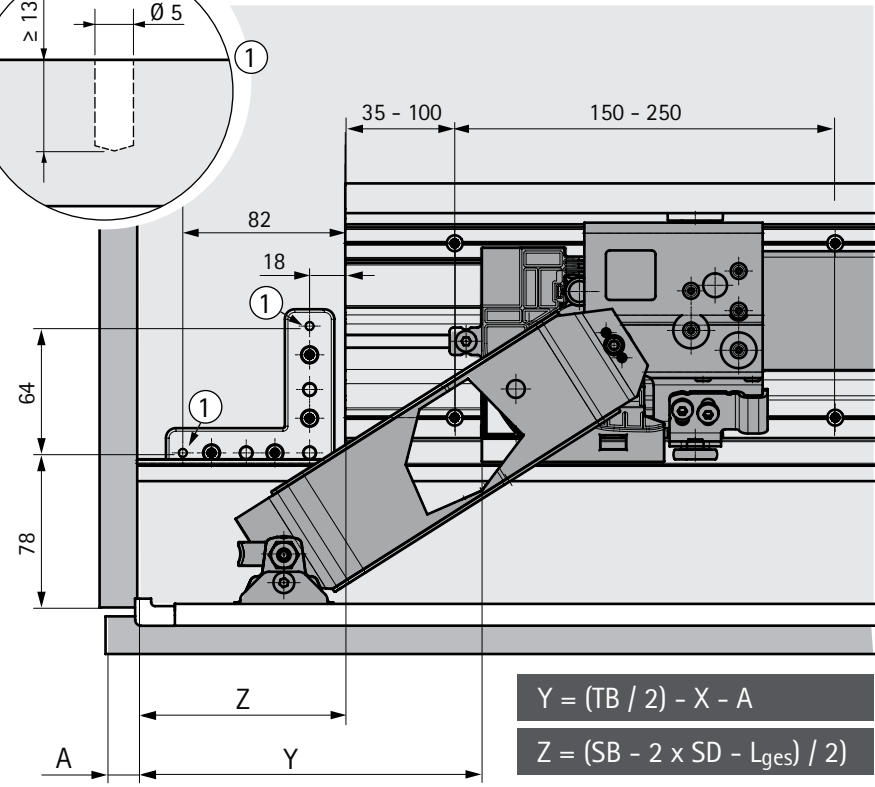
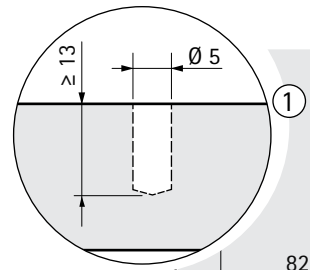
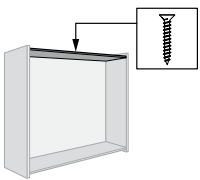
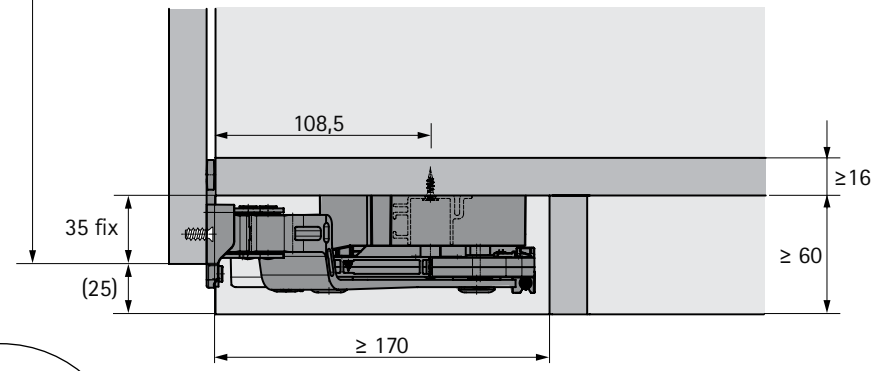
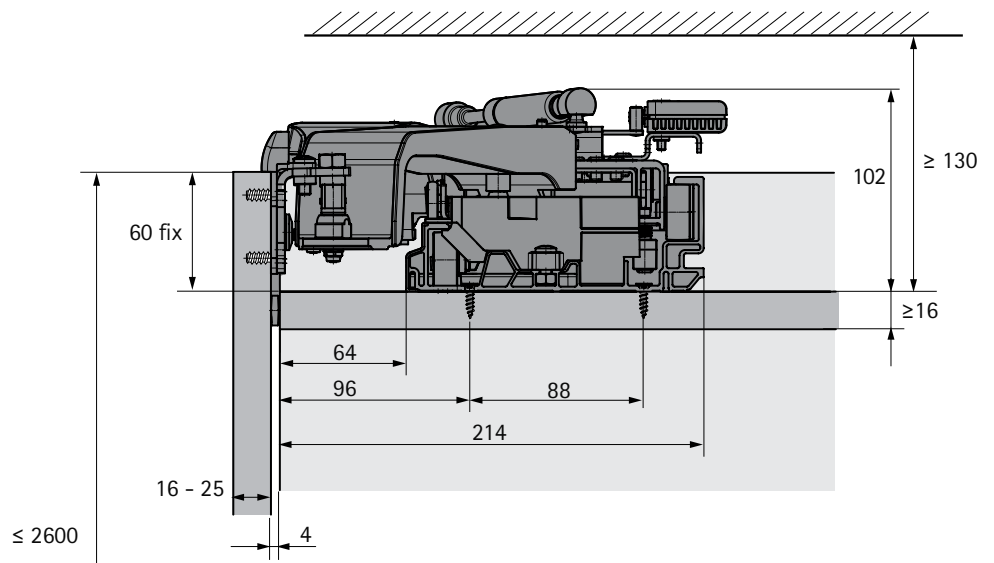

$$Y = (TB / 2) - X - A$$

$$Z = (SB - 2 \times SD - L_{ges}) / 2$$



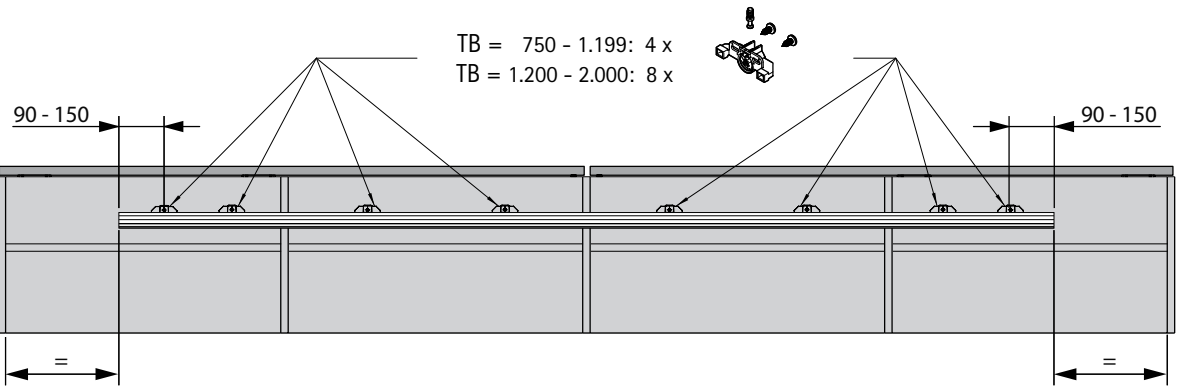
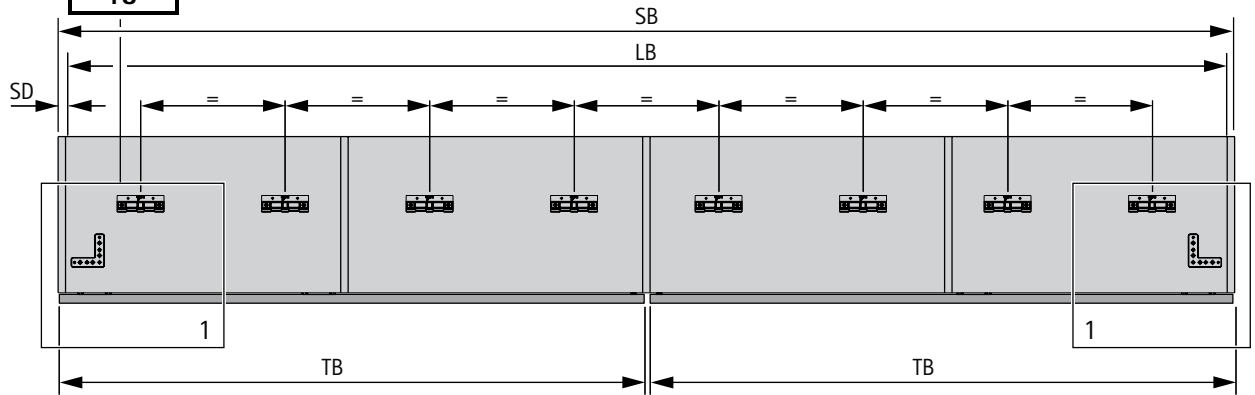

TB = 750 - 1.199: 4 x
 TB = 1.200 - 2.000: 8 x

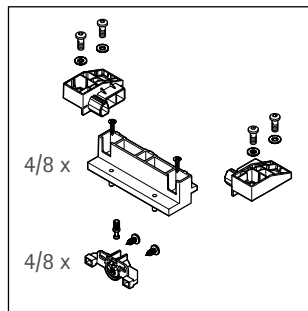

TB = 750 - 1.199: 9 148 547
 TB = 1.200 - 2.000: 9 148 562

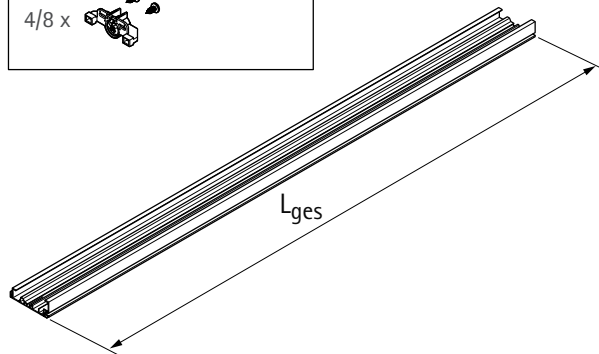

| TB | L _{ges} | X | A (max) |
|-------------|------------------|-------|---------|
| 750 - 819 | 1294 | 215,5 | 13 |
| 820 - 909 | 1434 | 240,5 | 13 |
| 910 - 1044 | 1606 | 260,5 | 17 |
| 1045 - 1199 | 1876 | 310,5 | 17 |
| 1200 - 1299 | 2164 | 410,5 | 28 |
| 1300 - 1499 | 2364 | 410,5 | 28 |
| 1500 - 1599 | 2764 | 560,5 | 28 |
| 1600 - 1799 | 2964 | 560,5 | 28 |
| 1800 - 1899 | 3364 | 710,5 | 28 |
| 1900 - 2000 | 3564 | 710,5 | 28 |



* 9 148 547
9 148 562

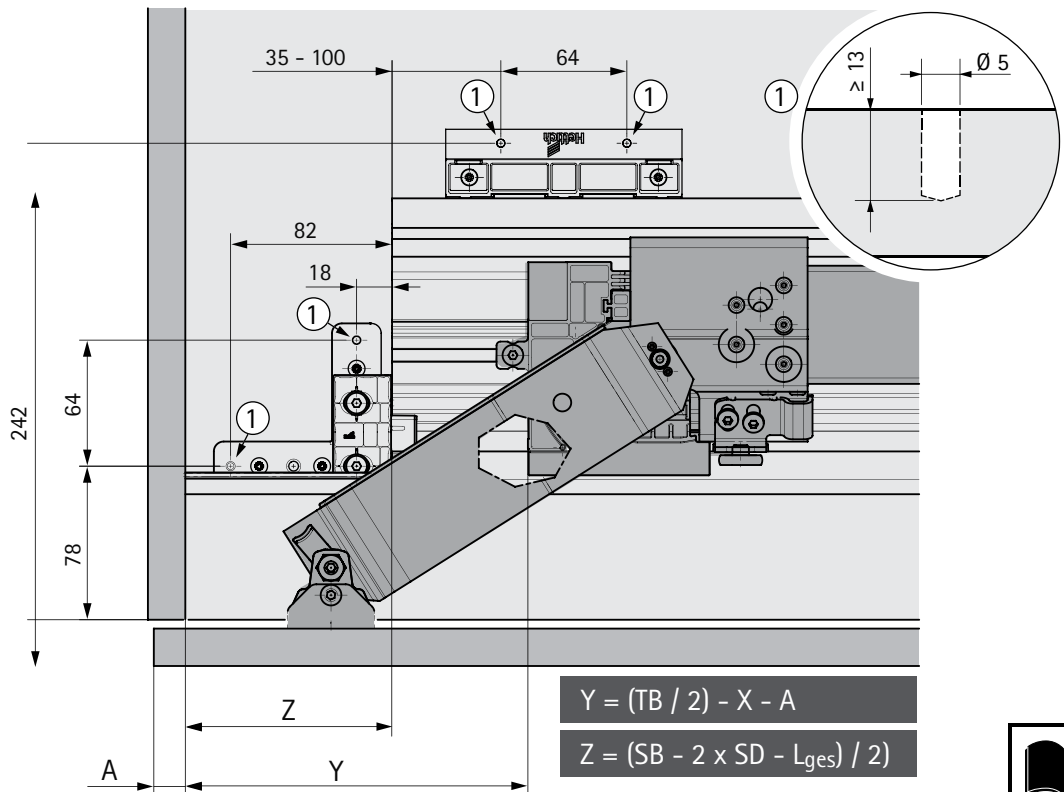
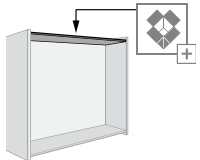
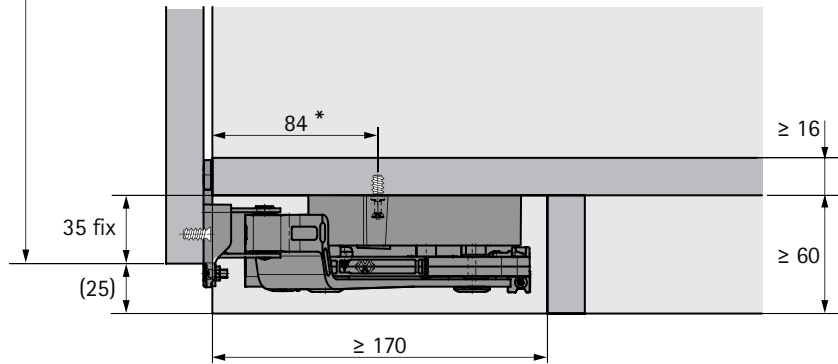
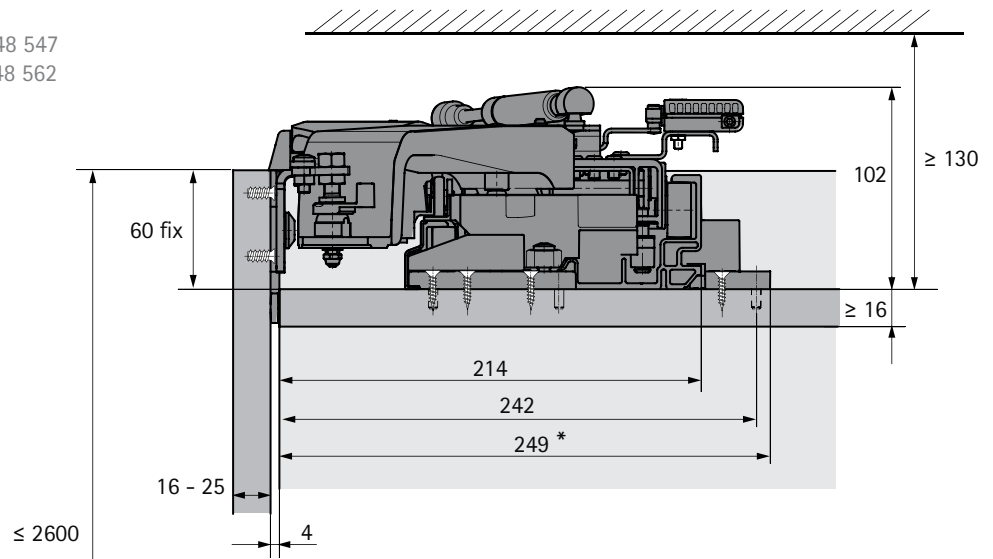

$$Y = (TB / 2) - X - A$$

$$Z = (SB - 2 \times SD - L_{ges}) / 2$$



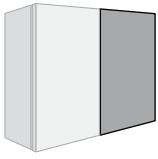

| TB | a | b |
|-------------|-----|----|
| 750 - 819 | 133 | 16 |
| 820 - 909 | 158 | 16 |
| 910 - 1044 | 178 | 32 |
| 1045 - 1199 | 228 | 32 |
| 1200 - 1299 | 328 | 32 |
| 1300 - 1499 | 328 | 32 |
| 1500 - 1599 | 478 | 32 |
| 1600 - 1799 | 478 | 32 |
| 1800 - 1899 | 628 | 32 |
| 1900 - 2000 | 628 | 32 |

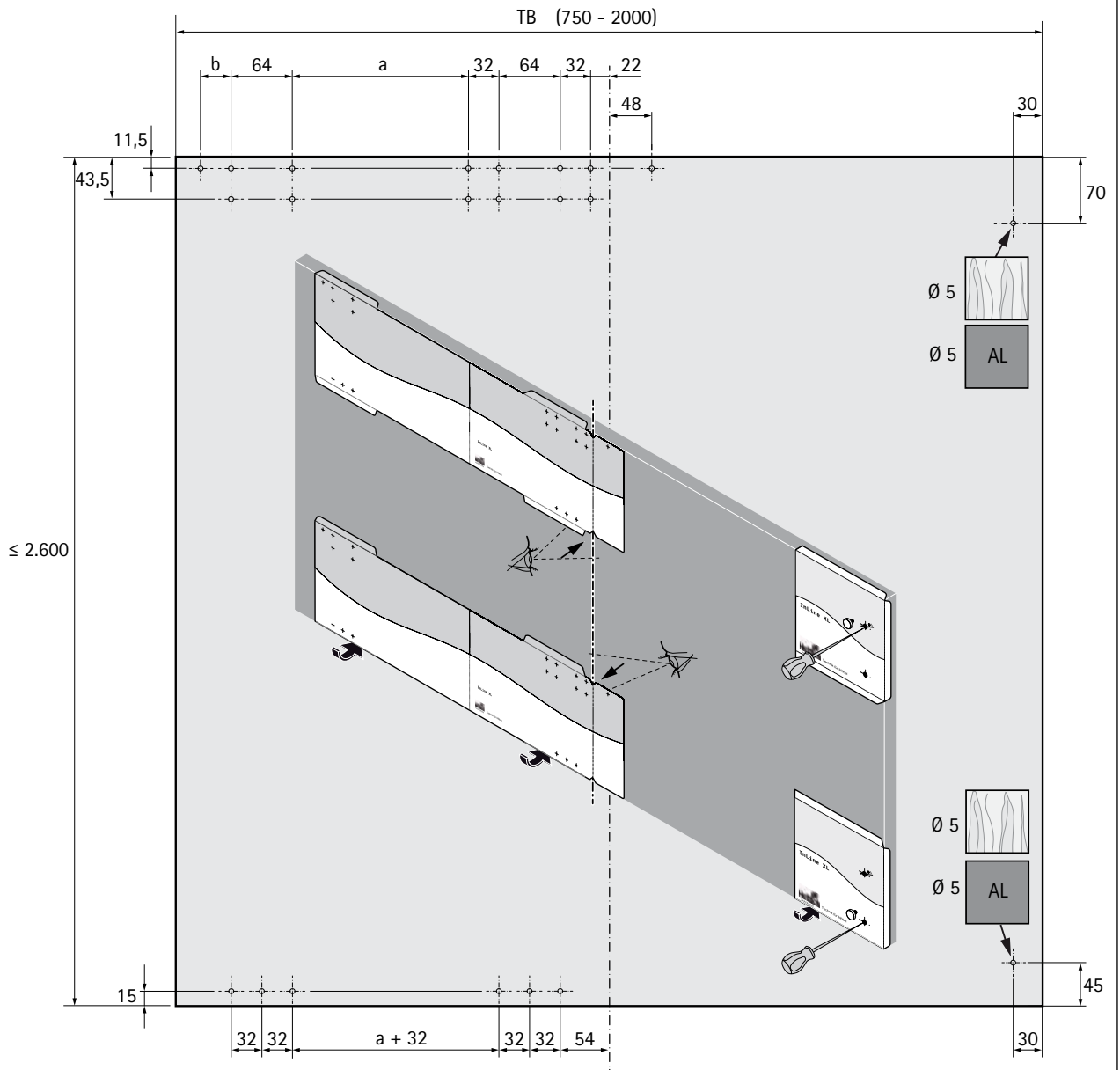
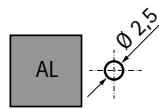
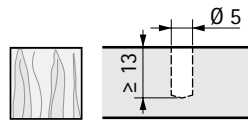

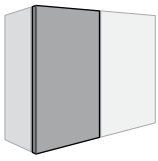

| TB | a | b |
|-------------|-----|----|
| 750 - 819 | 133 | 16 |
| 820 - 909 | 158 | 16 |
| 910 - 1044 | 178 | 32 |
| 1045 - 1199 | 228 | 32 |
| 1200 - 1299 | 328 | 32 |
| 1300 - 1499 | 328 | 32 |
| 1500 - 1599 | 478 | 32 |
| 1600 - 1799 | 478 | 32 |
| 1800 - 1899 | 628 | 32 |
| 1900 - 2000 | 628 | 32 |

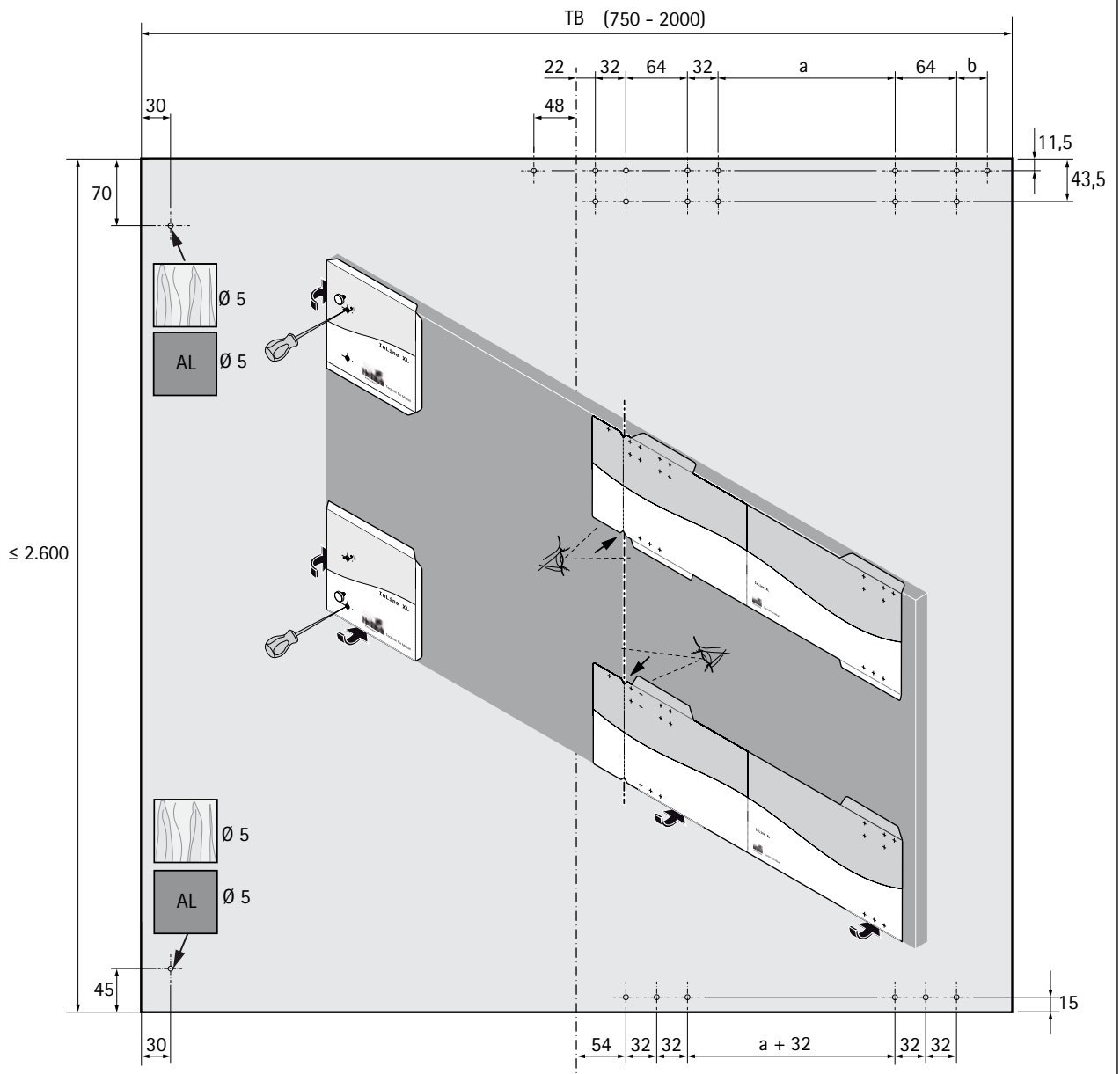
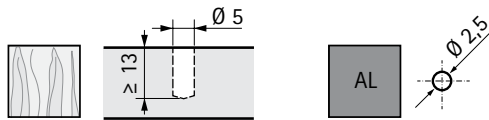

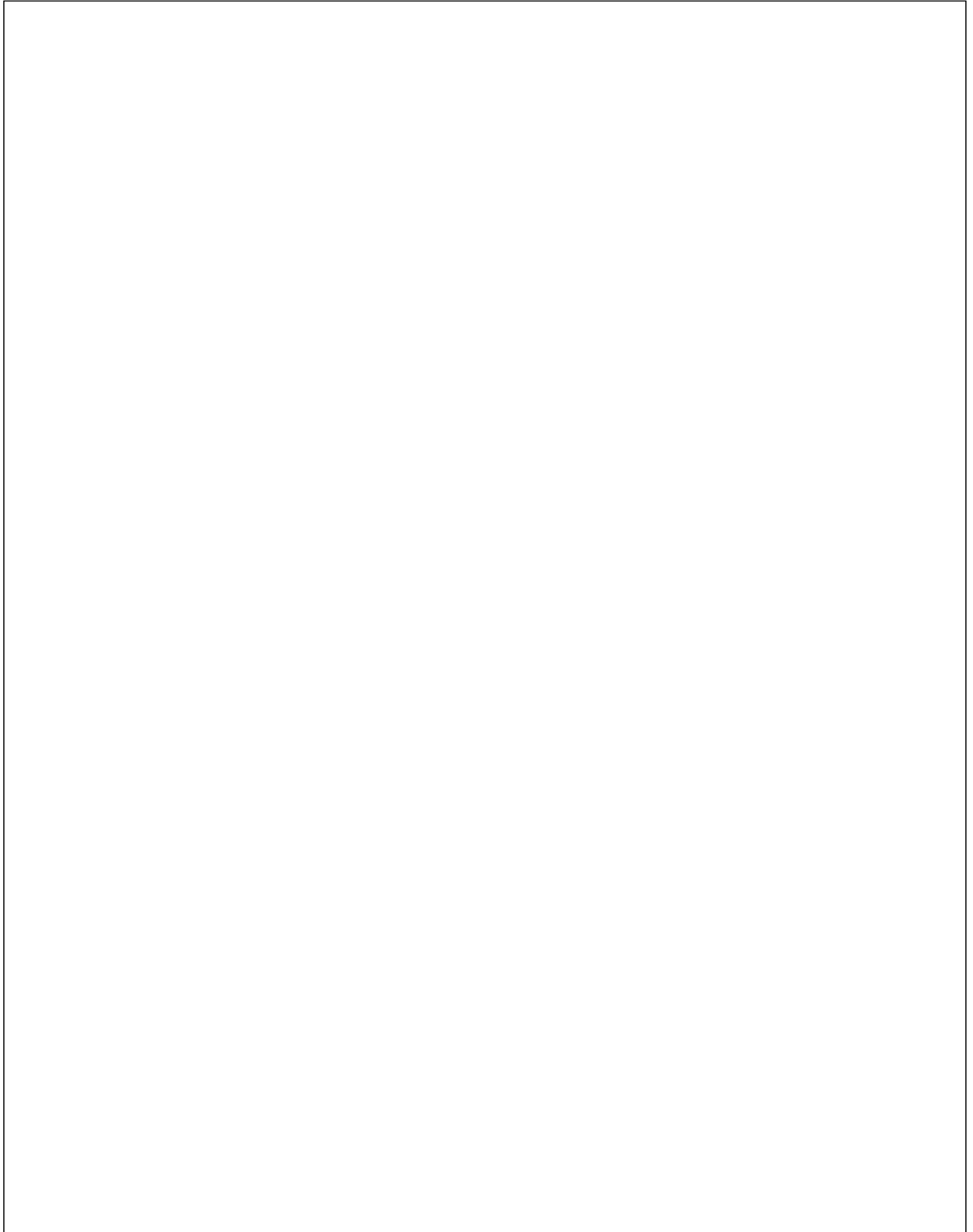

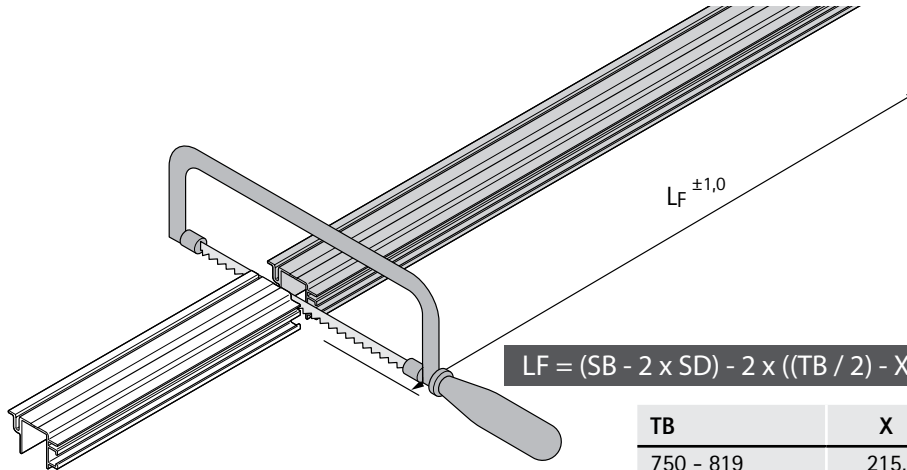
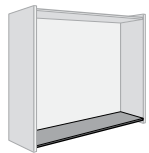
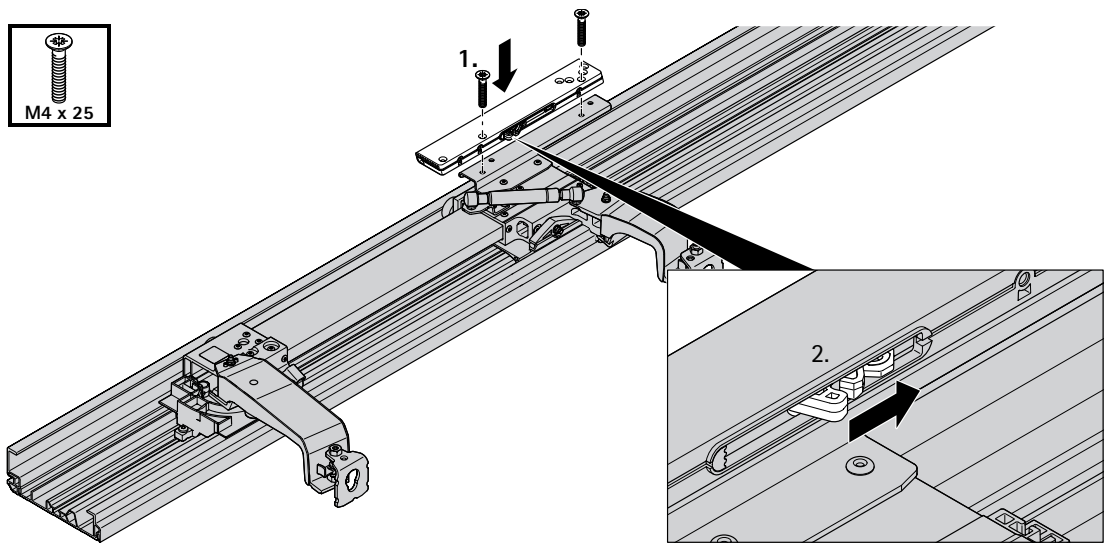

$$L_F = (SB - 2 \times SD) - 2 \times ((TB / 2) - X - A + 125,5)$$

| TB | X |
|-------------|-------|
| 750 - 819 | 215,5 |
| 820 - 909 | 240,5 |
| 910 - 1044 | 260,5 |
| 1045 - 1199 | 310,5 |
| 1200 - 1299 | 410,5 |
| 1300 - 1499 | 410,5 |
| 1500 - 1599 | 560,5 |
| 1600 - 1799 | 560,5 |
| 1800 - 1899 | 710,5 |
| 1900 - 2000 | 710,5 |

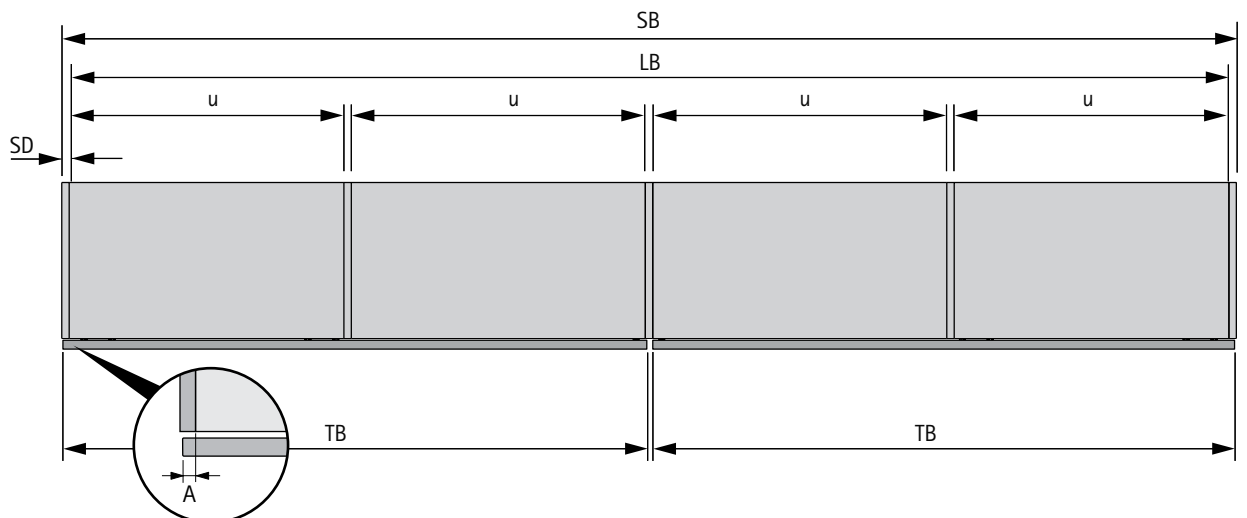

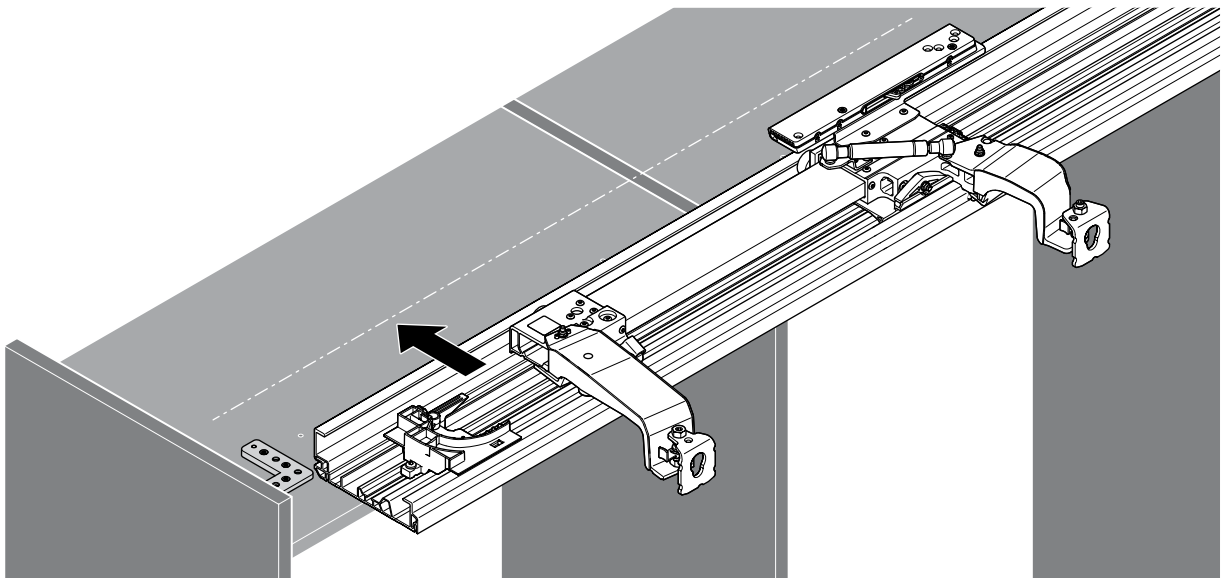
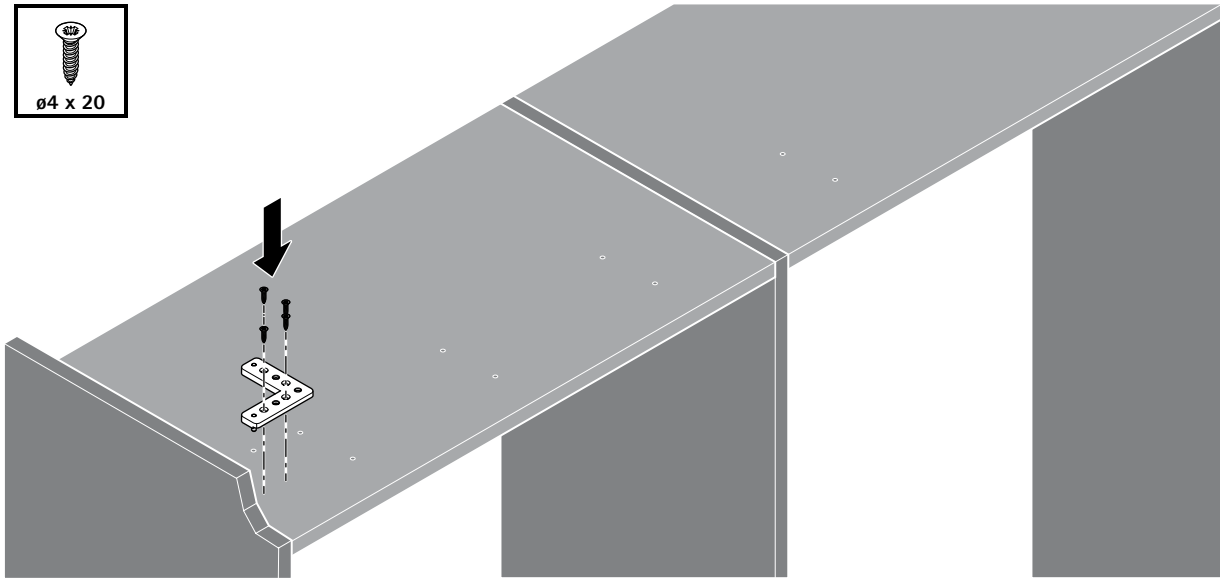

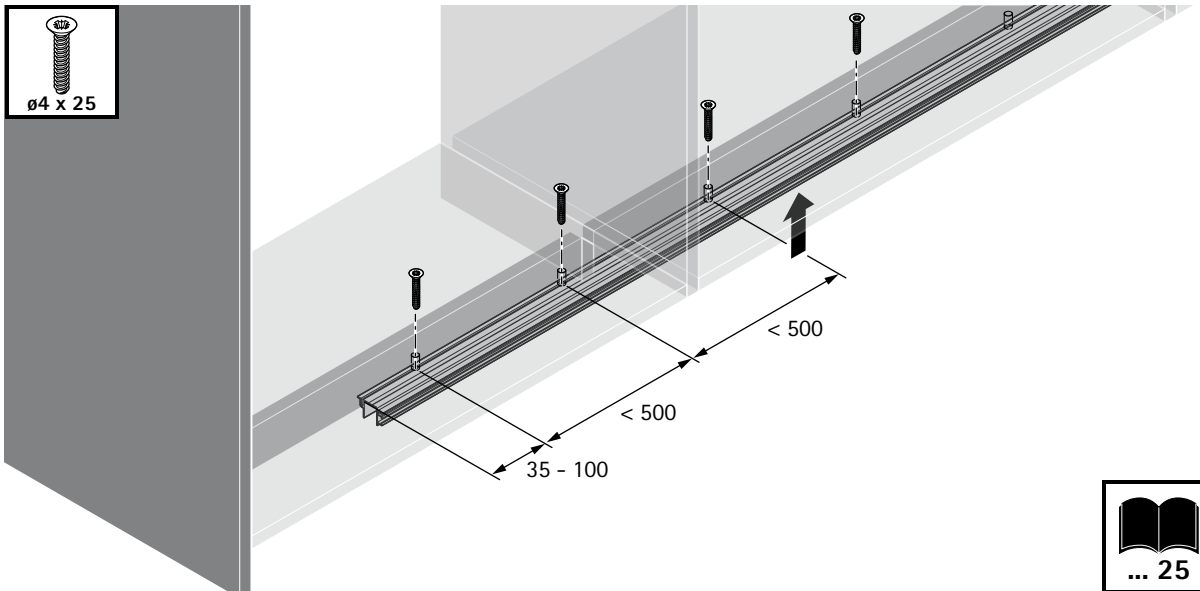
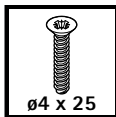
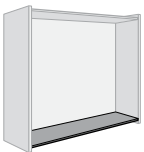
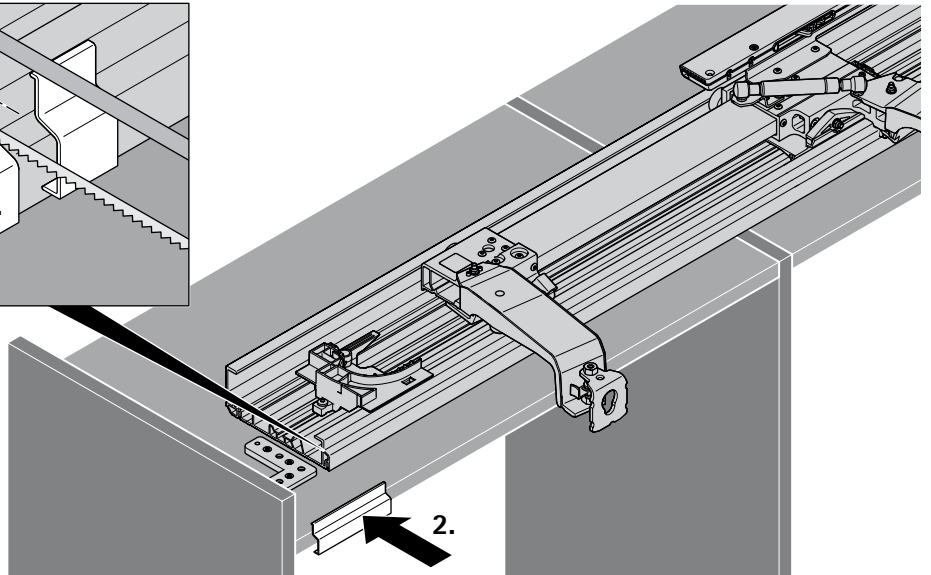
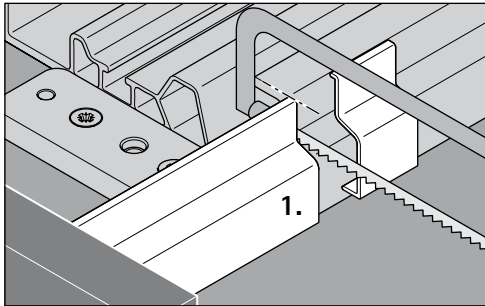
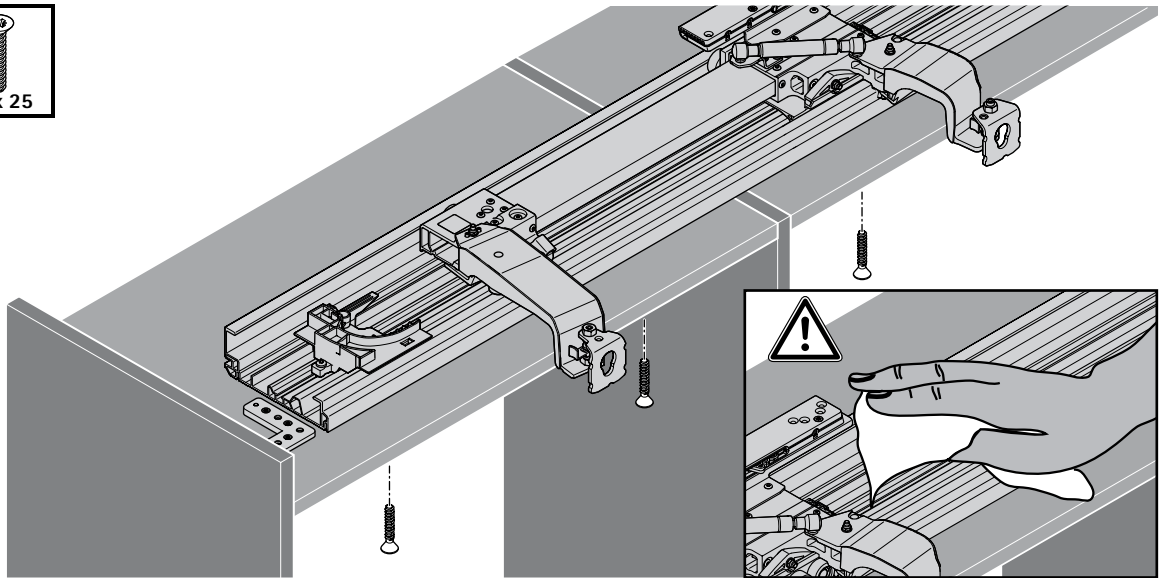
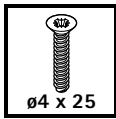

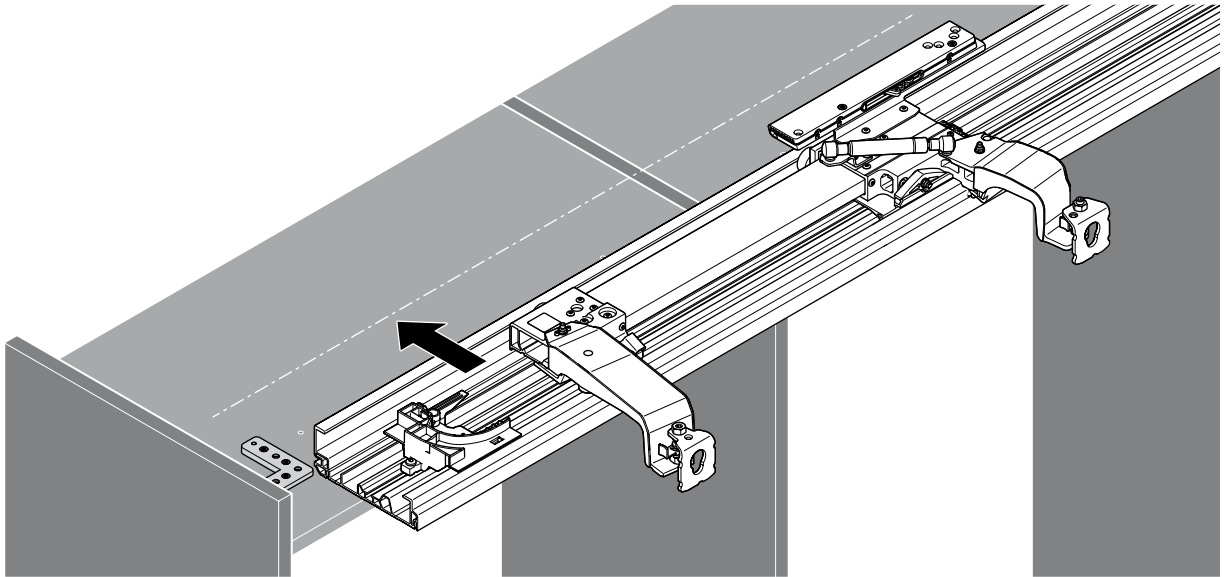
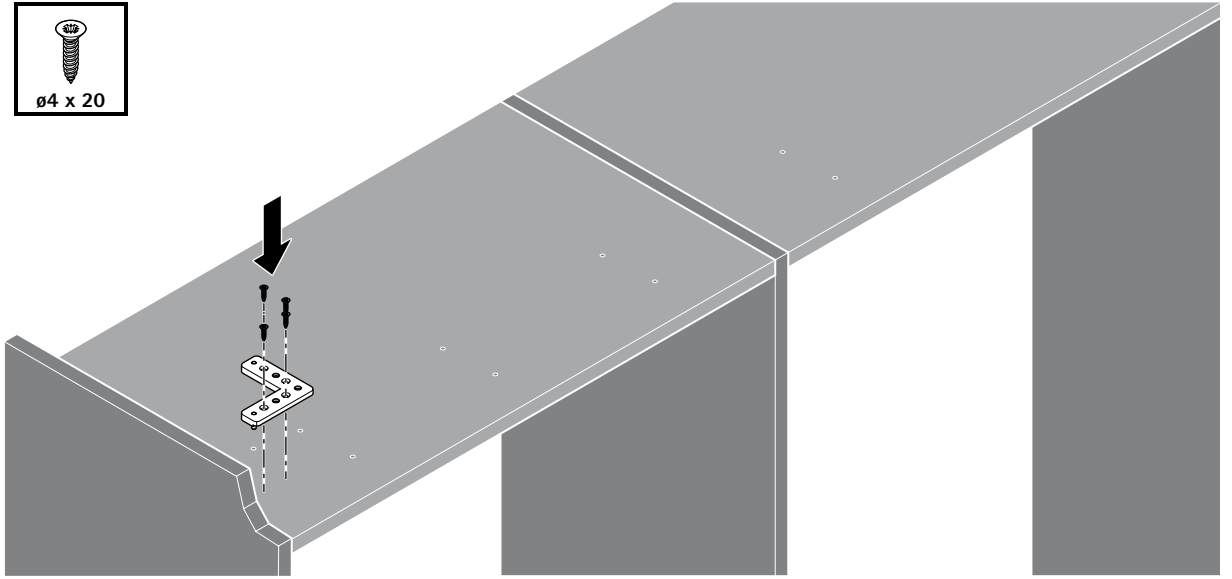

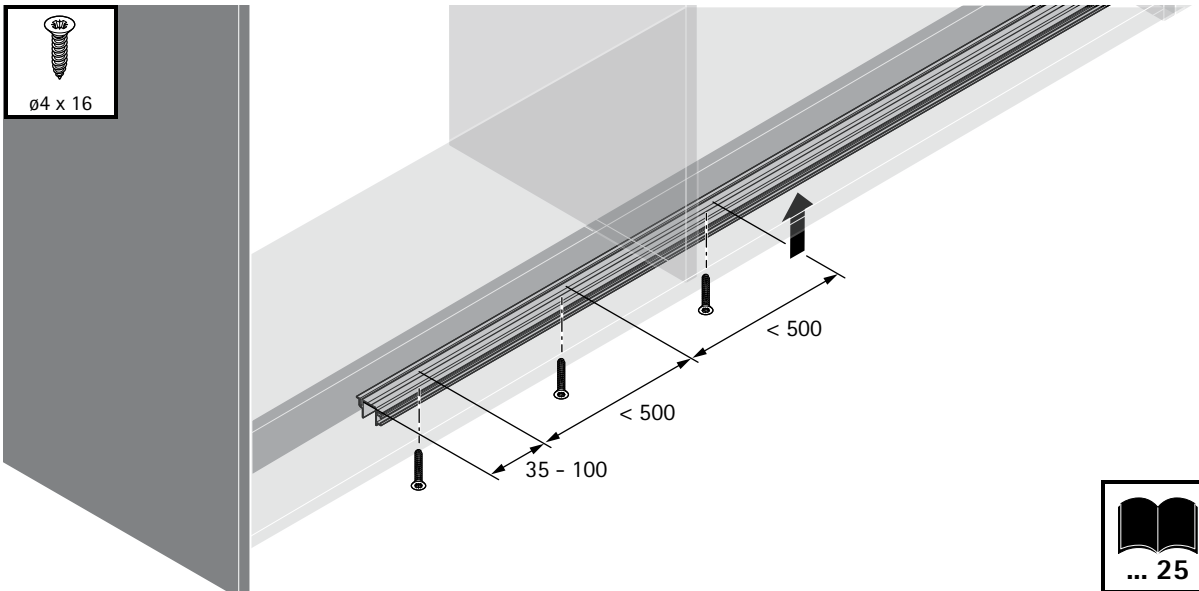
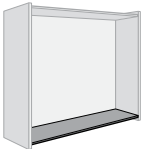
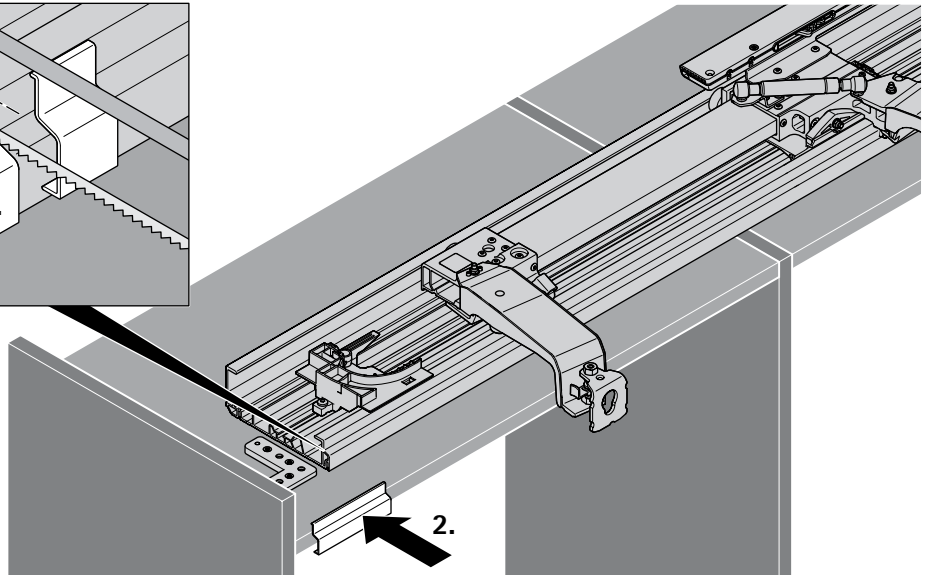
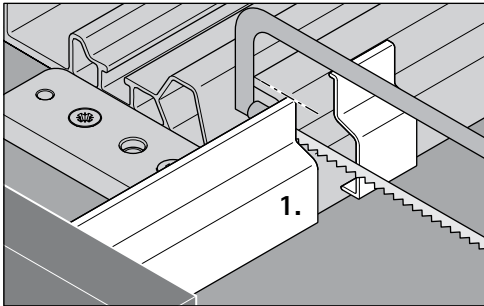
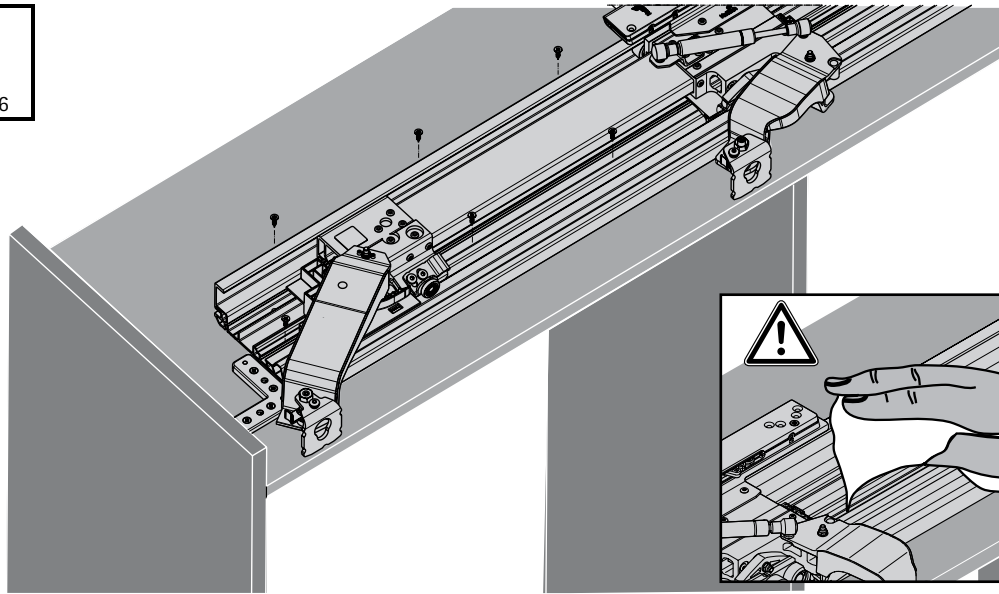
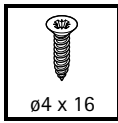

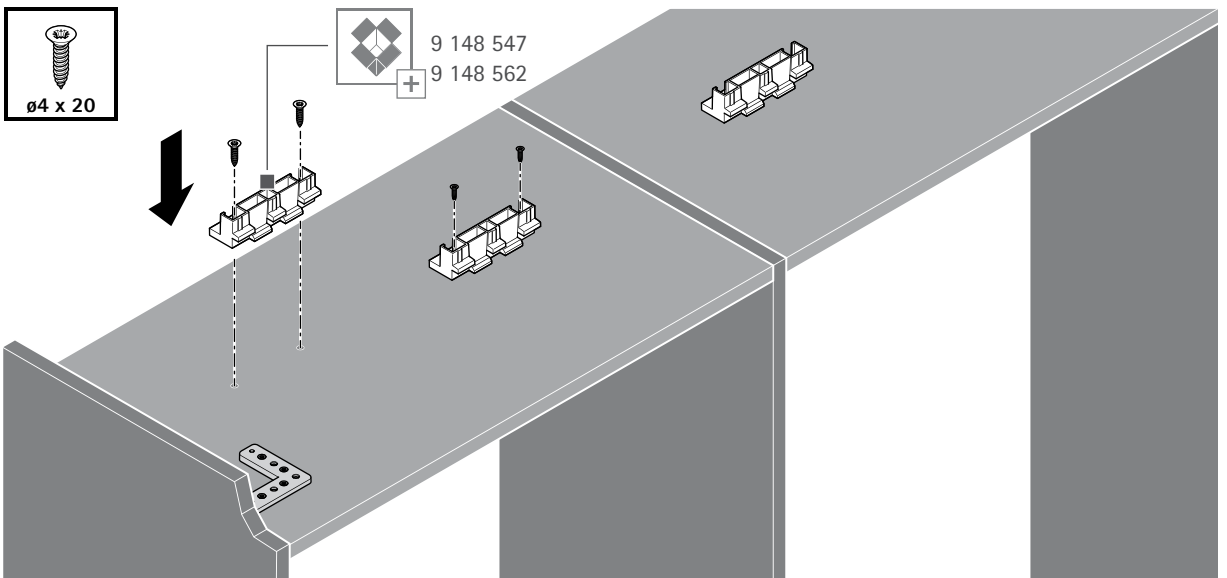
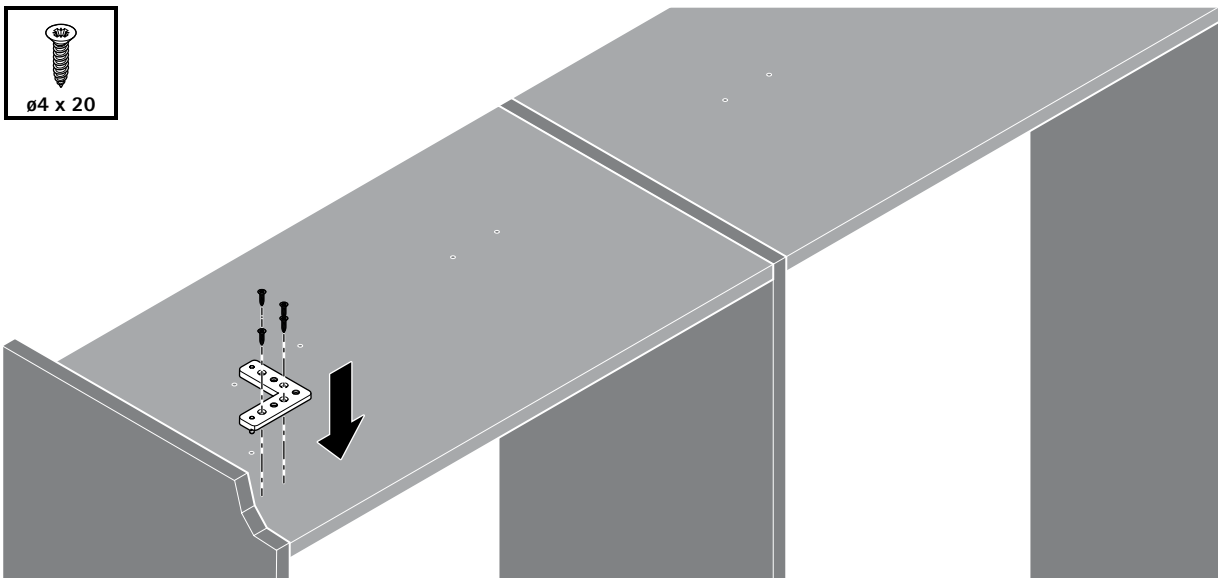
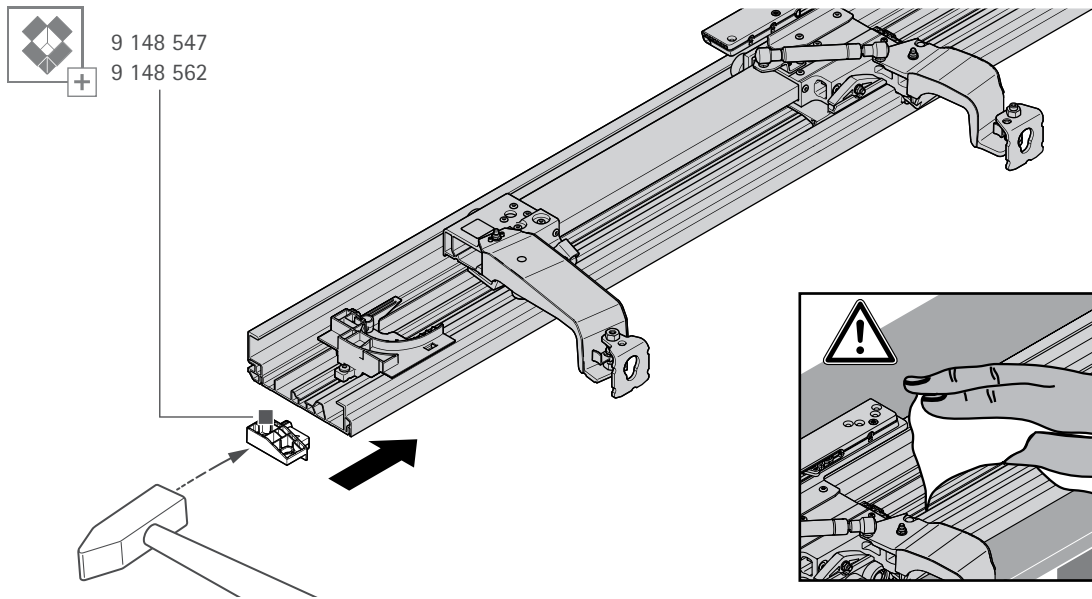

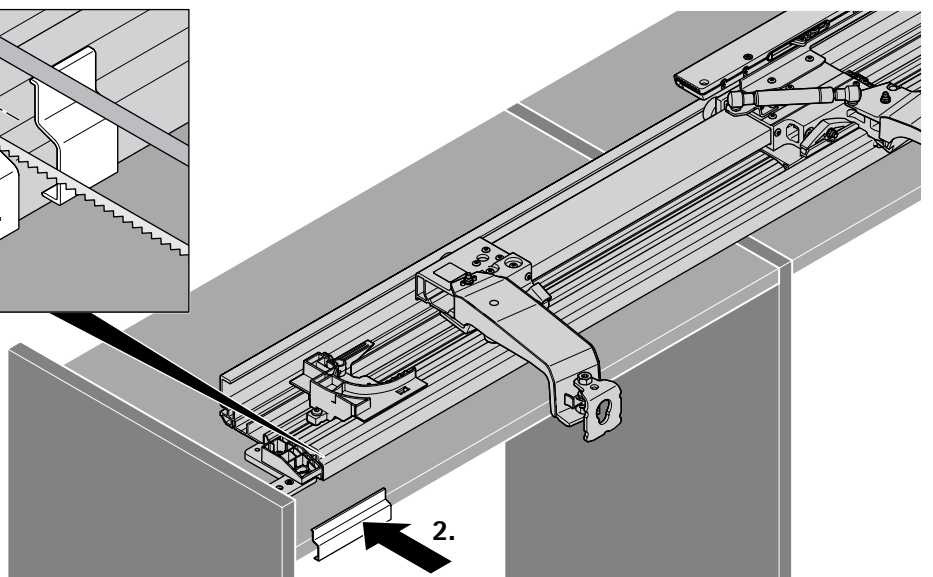
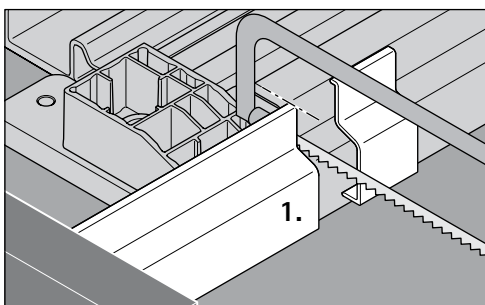
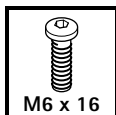
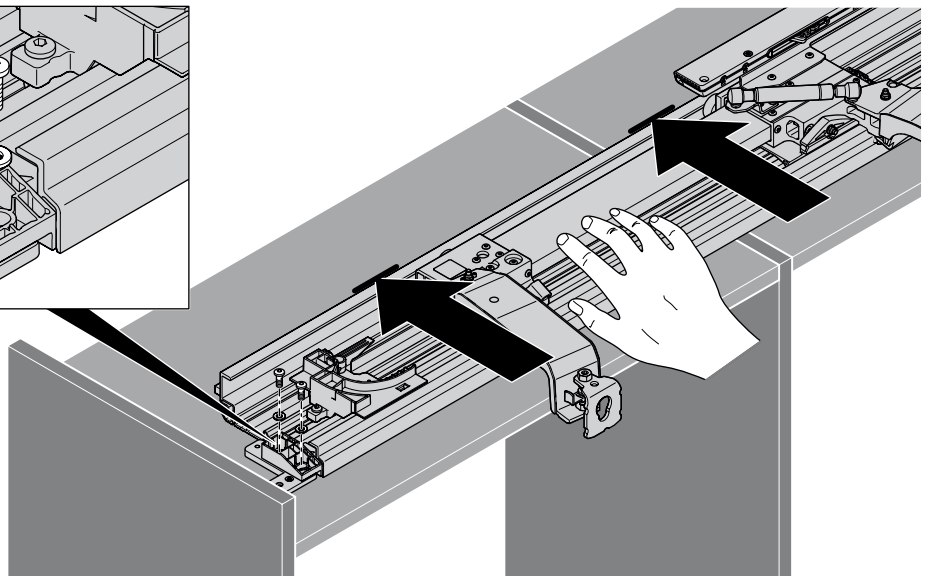
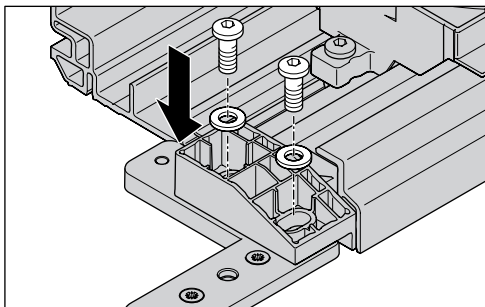
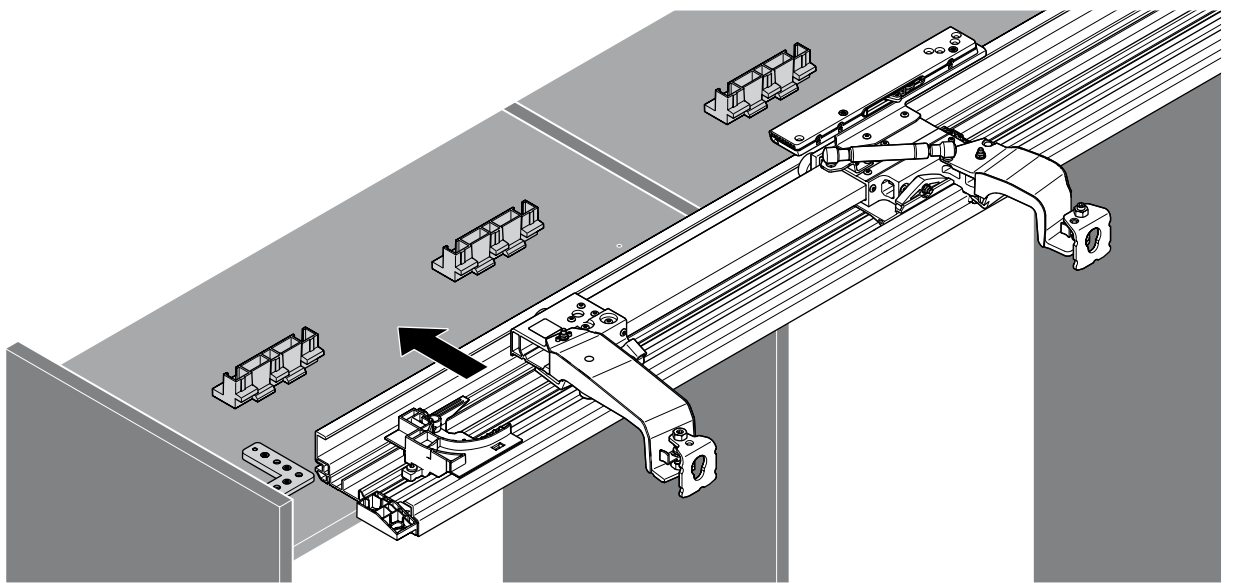

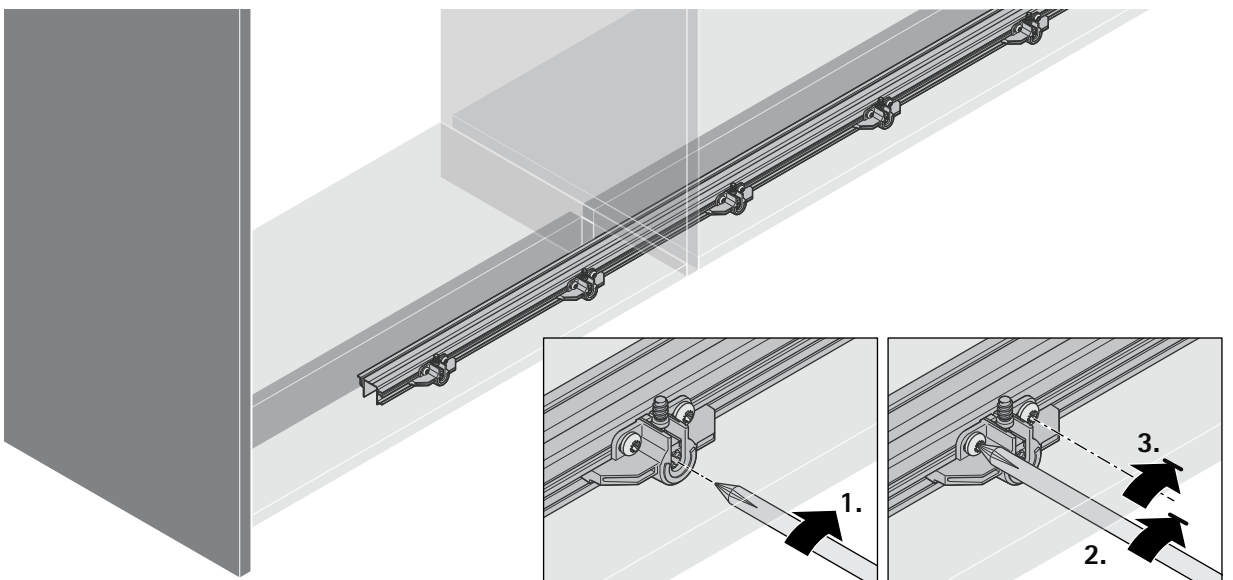
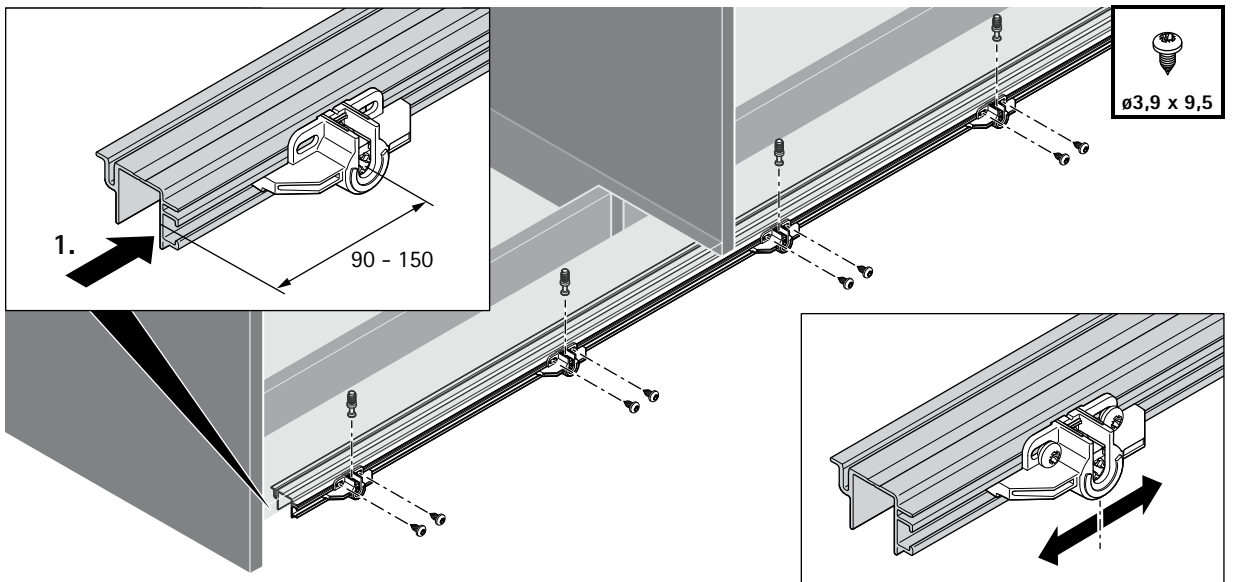
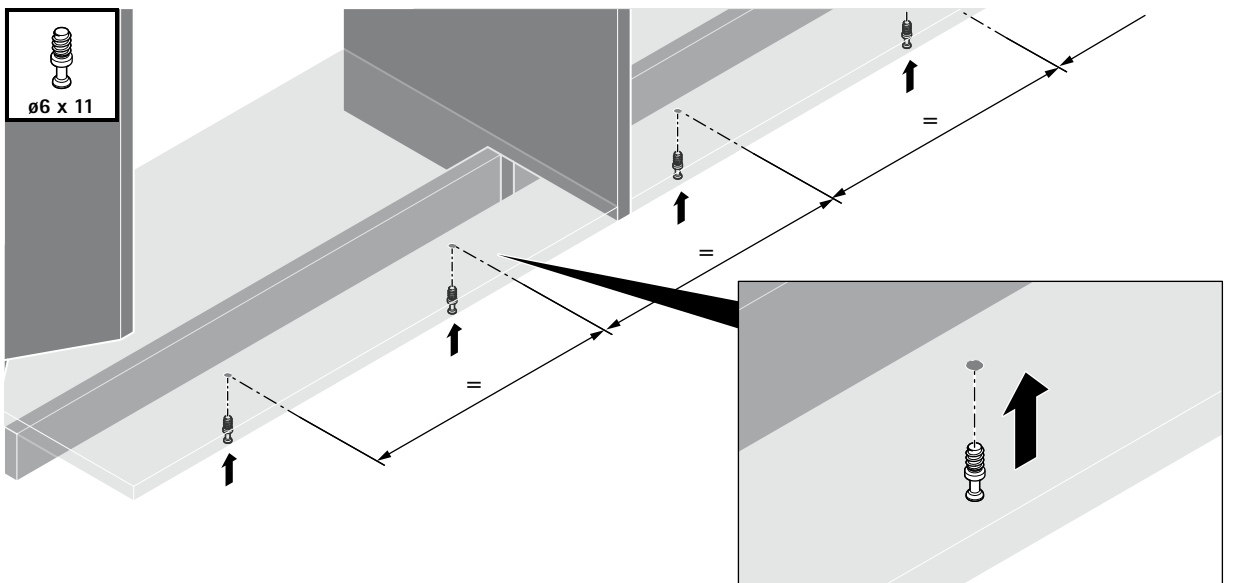

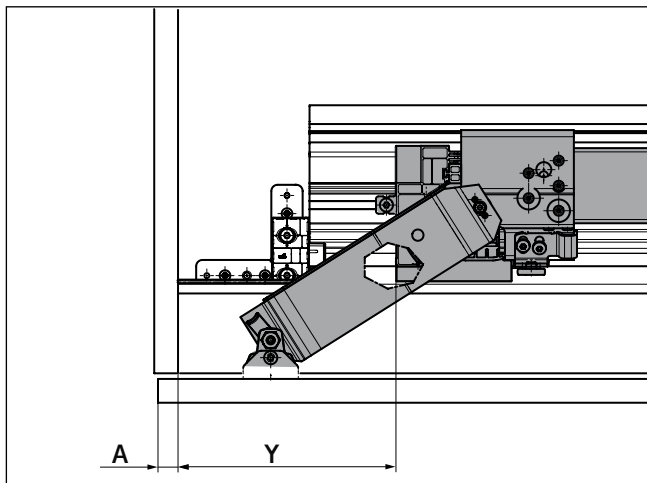
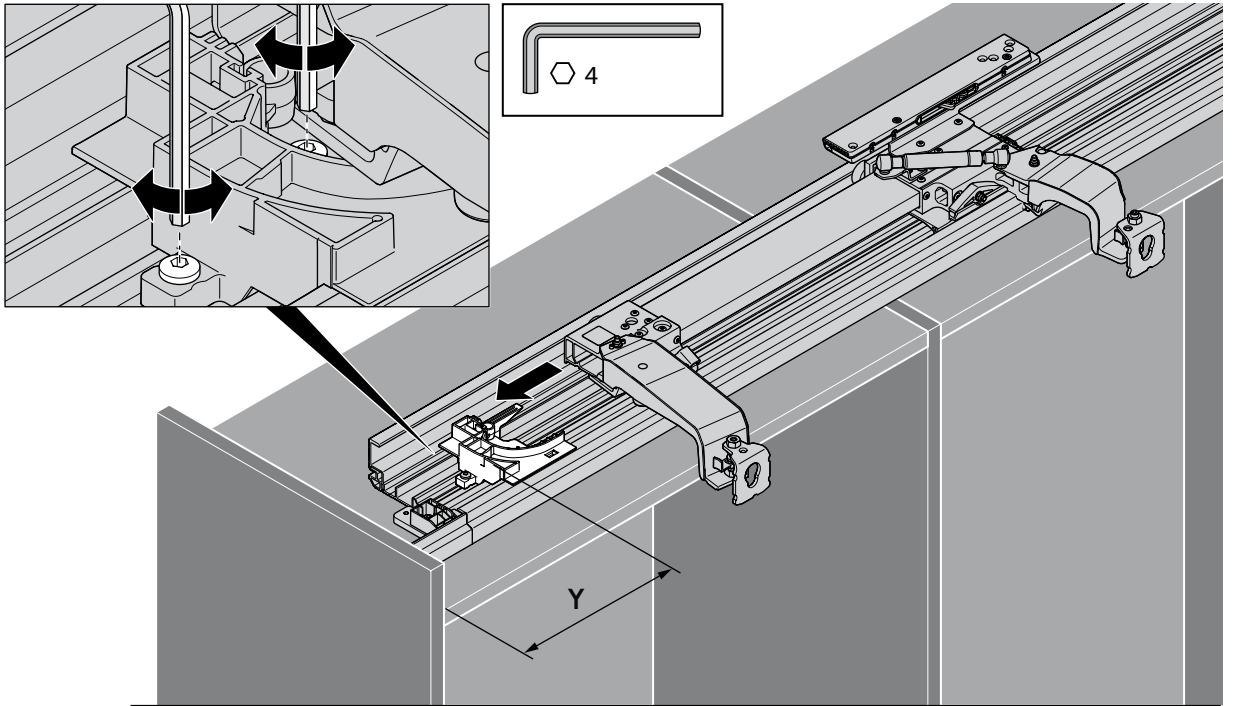

$$Y = (TB / 2) - X - A$$

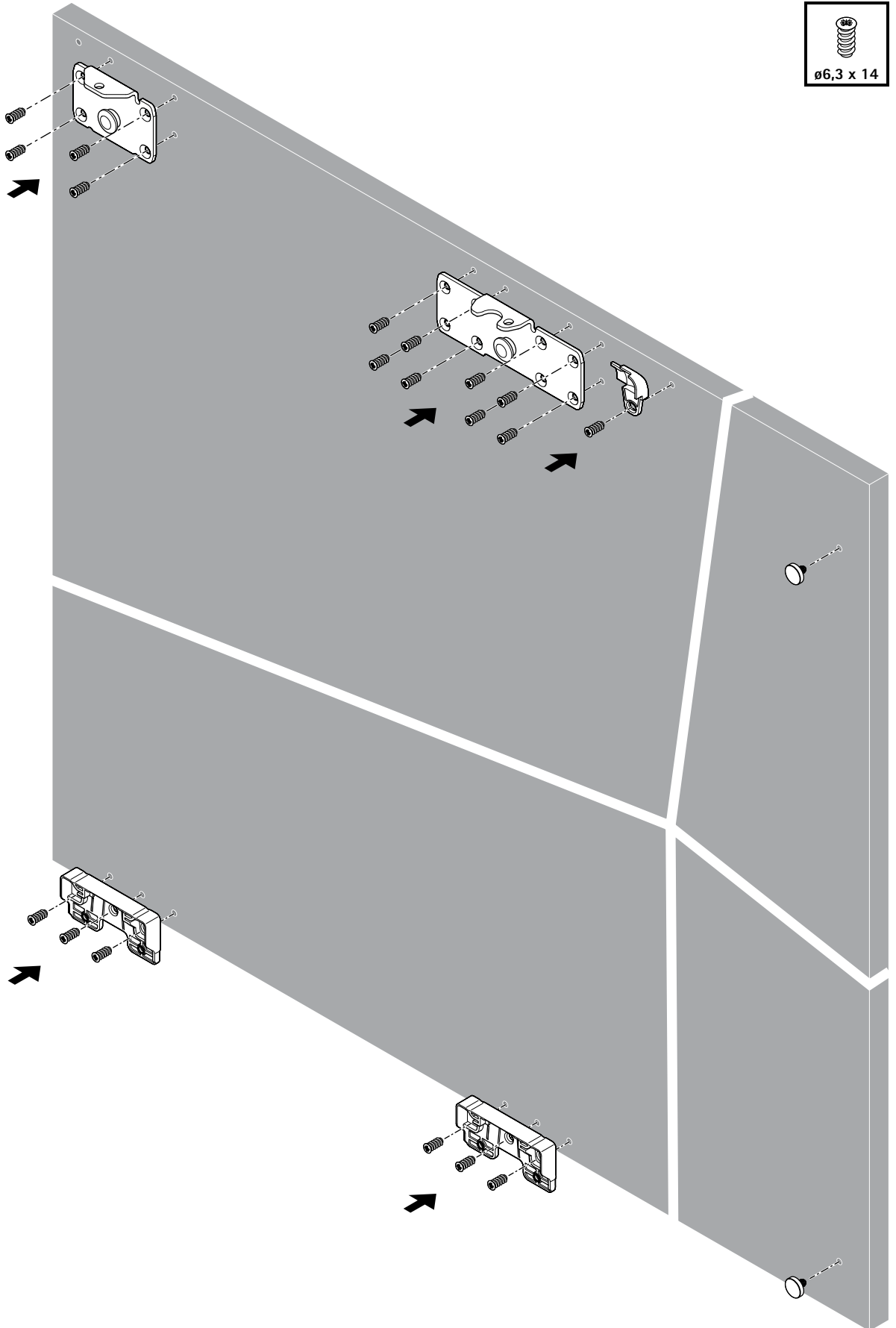
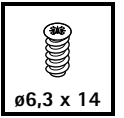
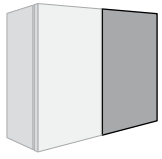

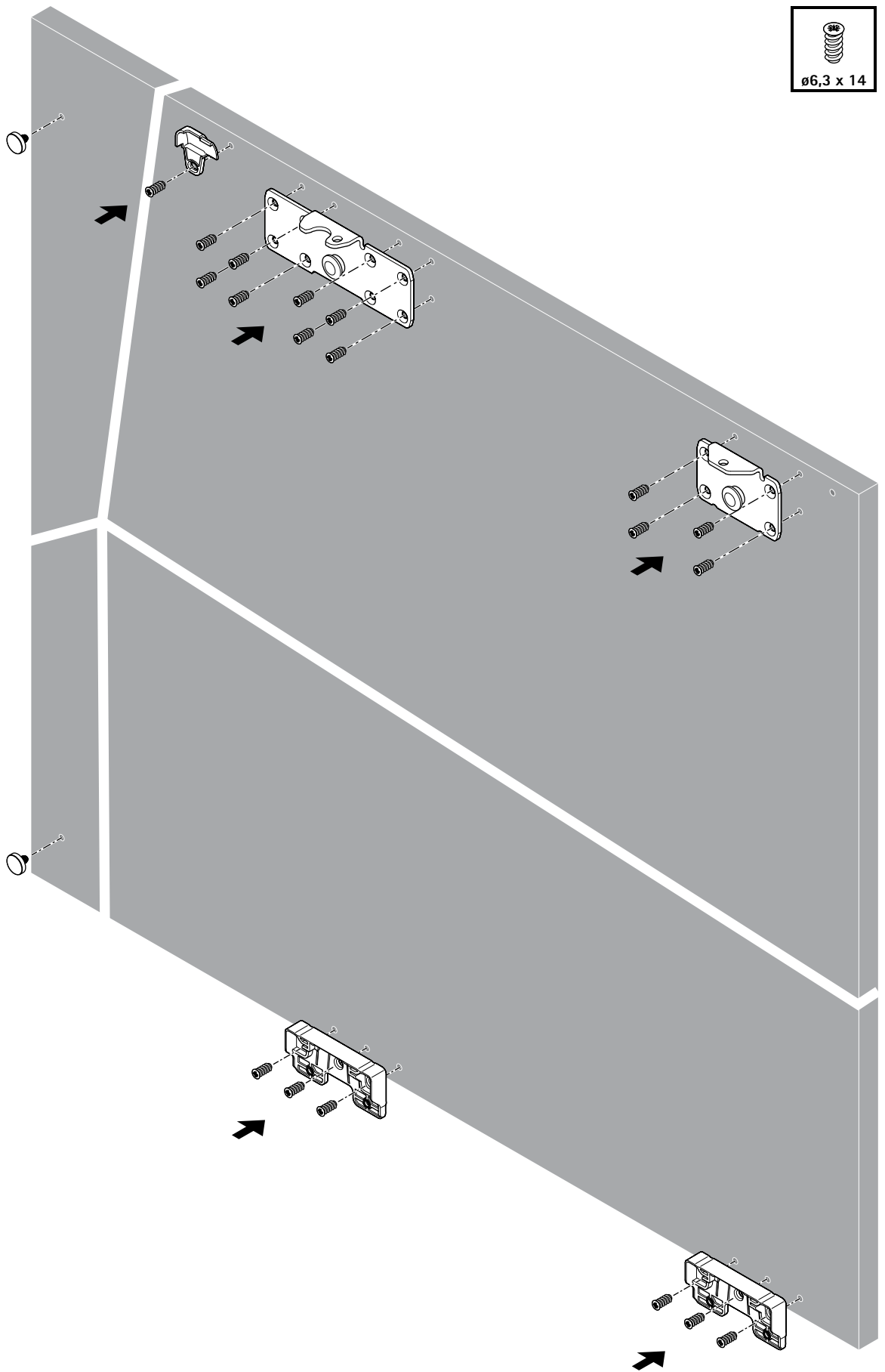
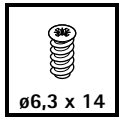
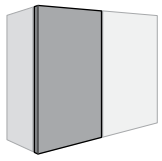

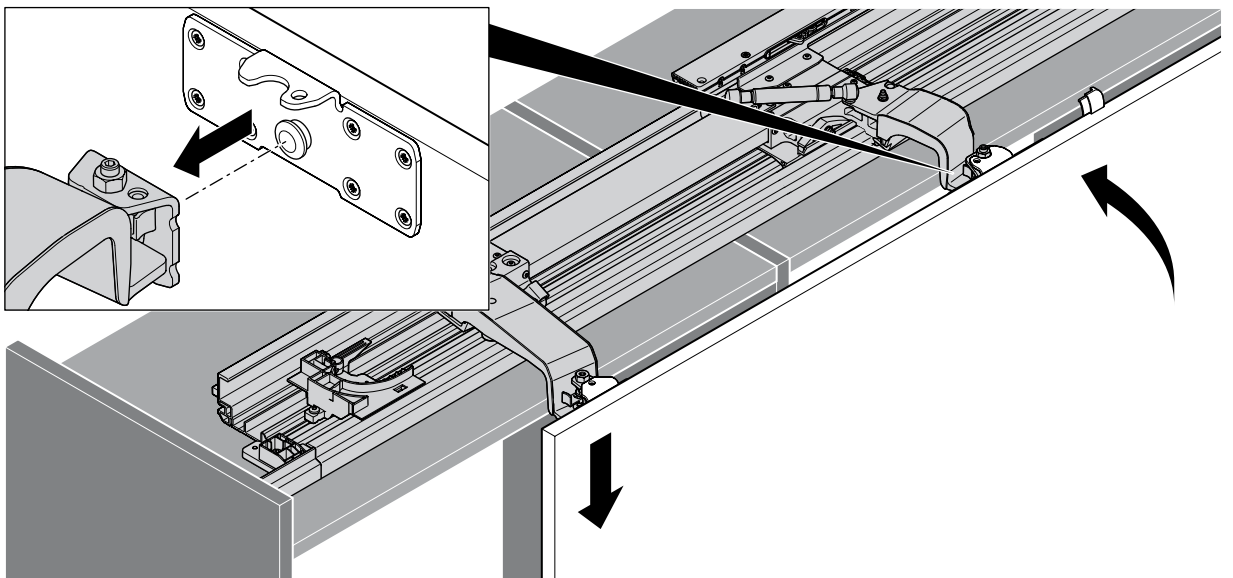
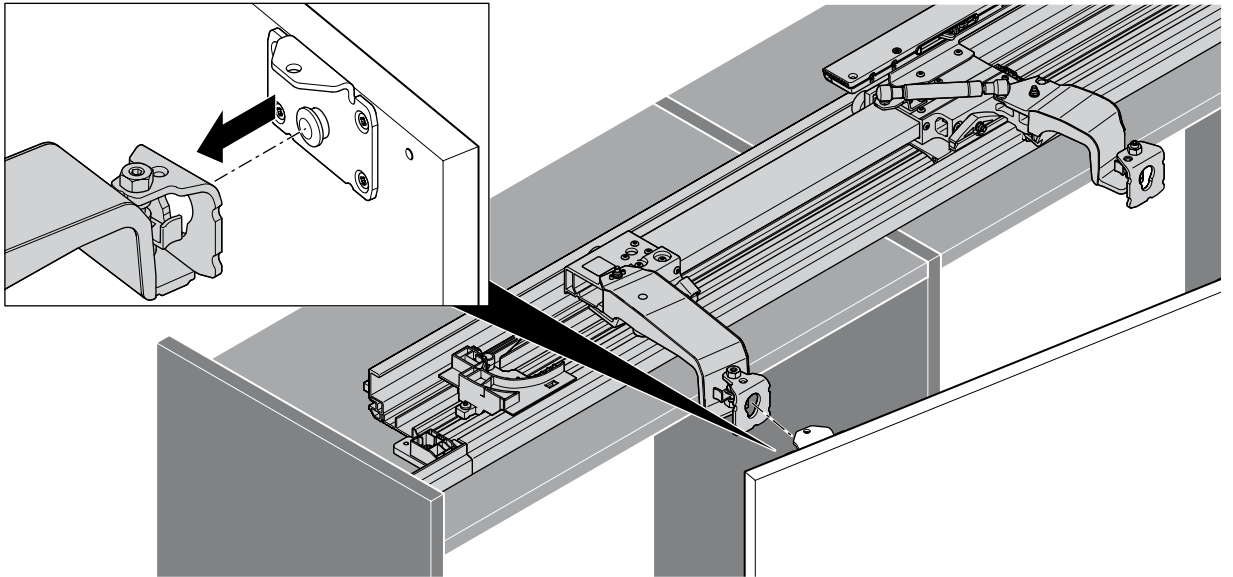
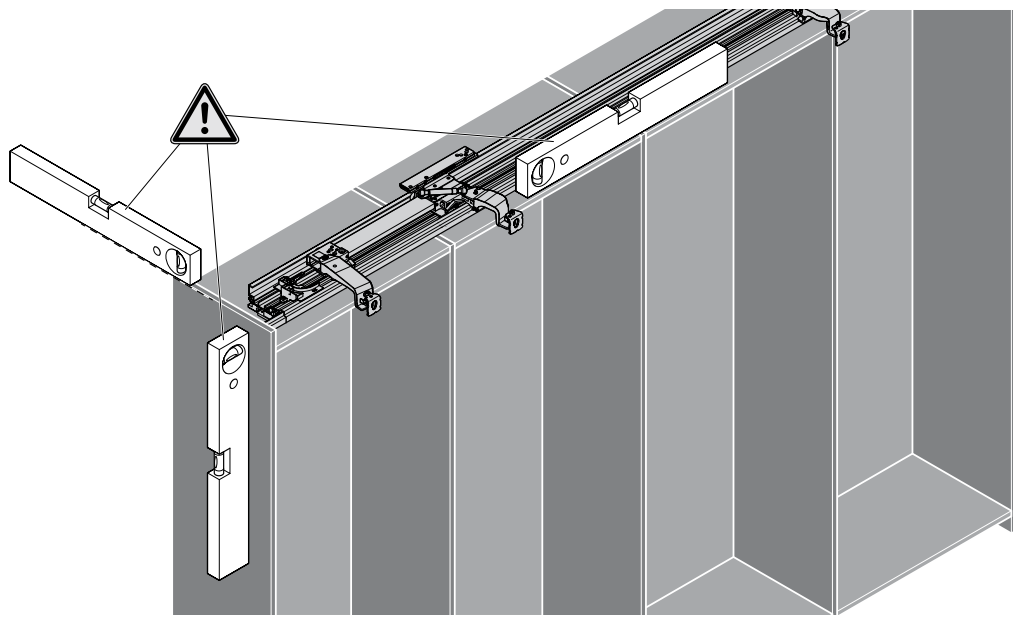

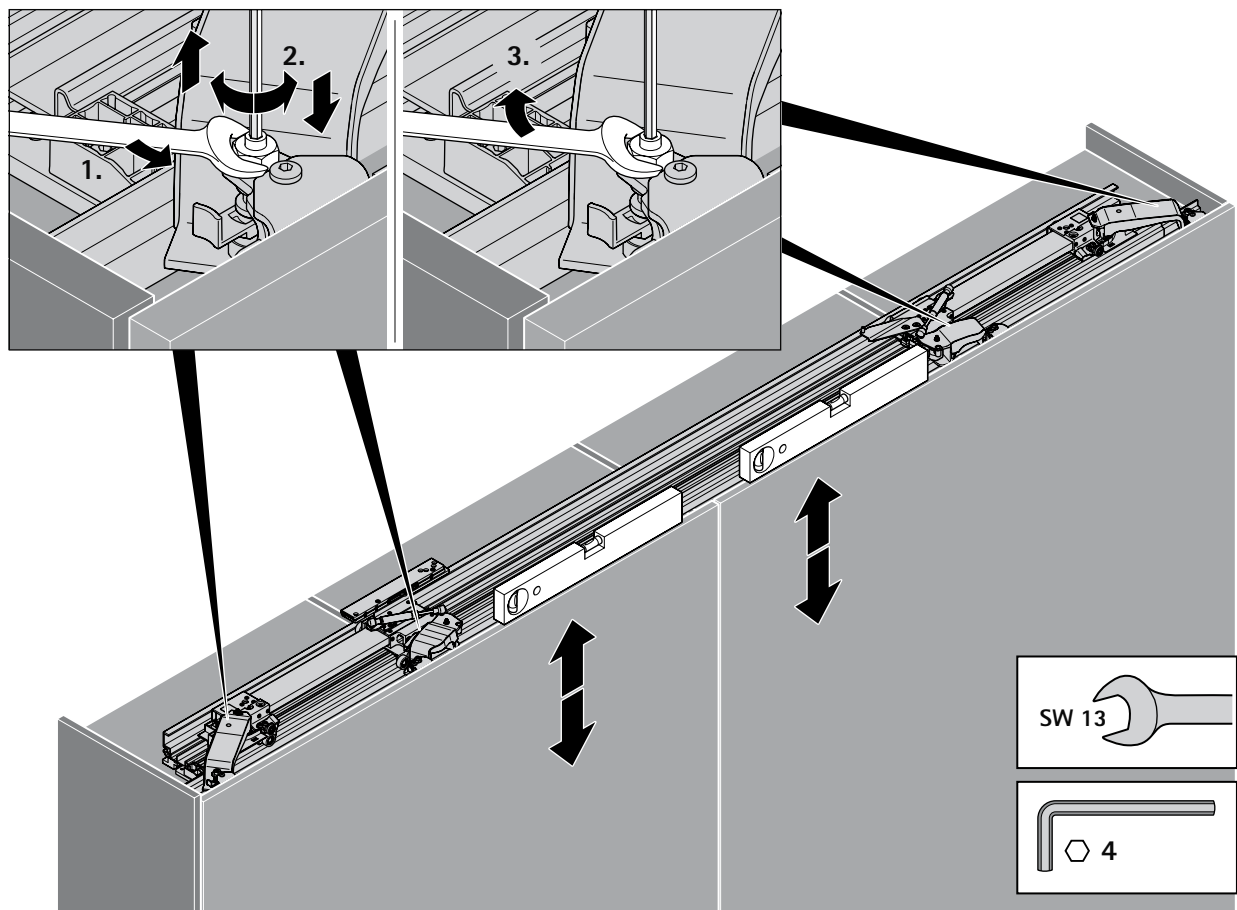
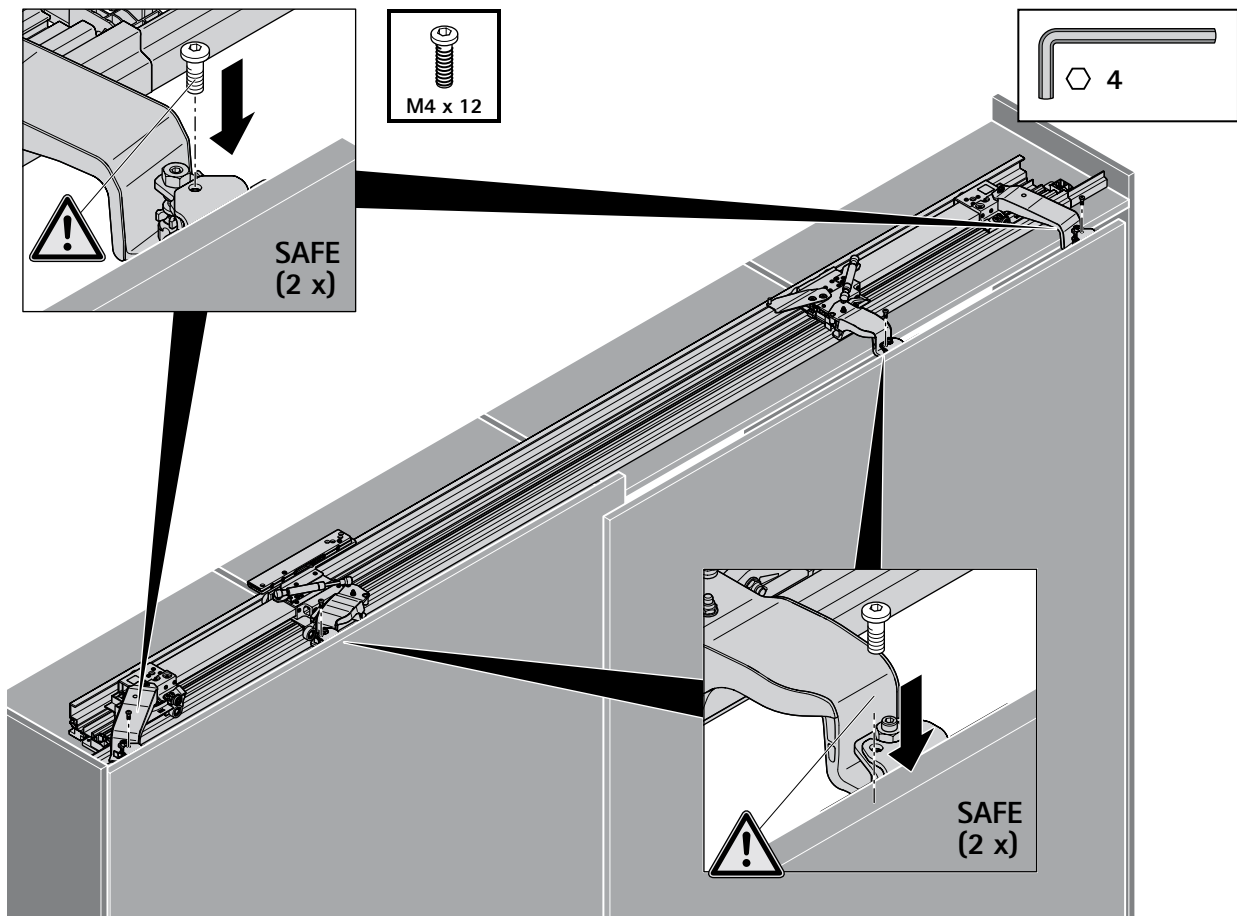

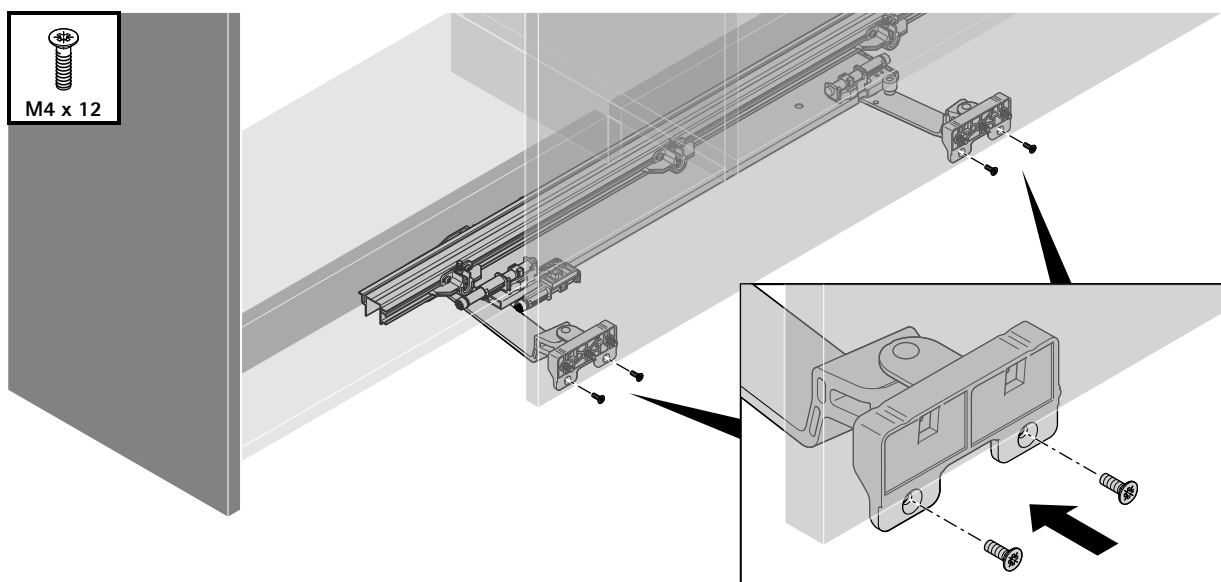
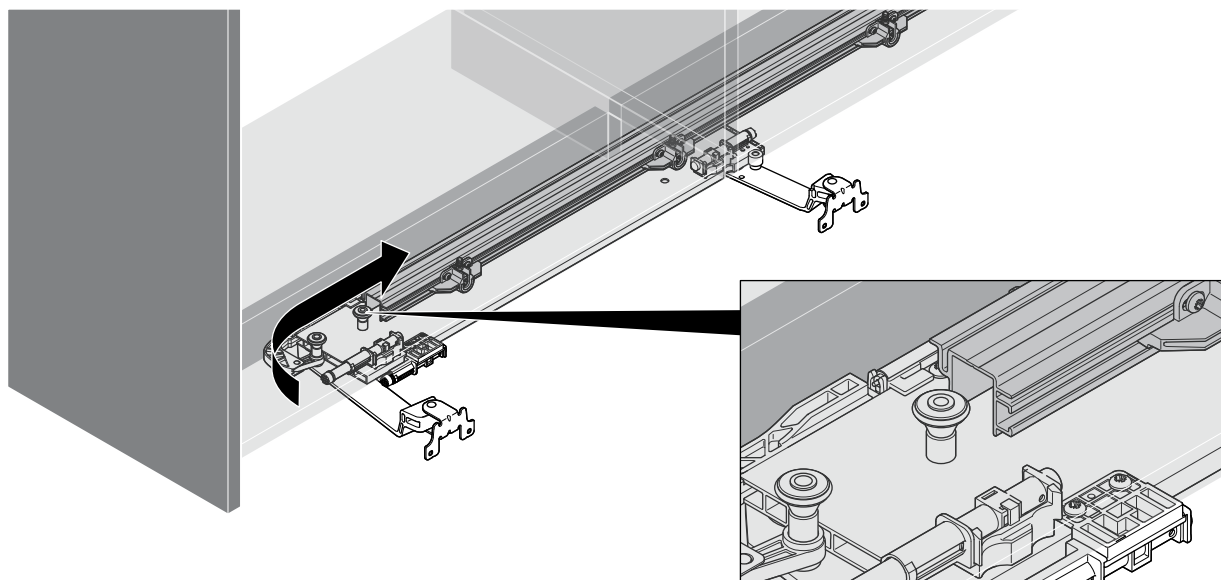
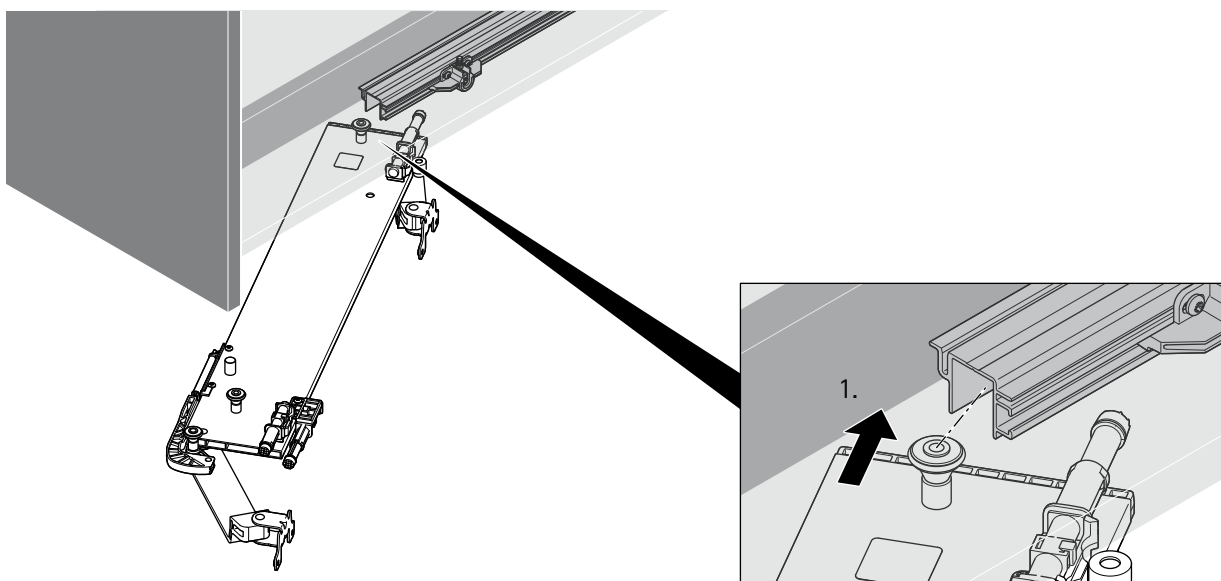
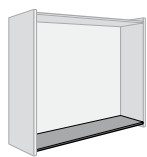

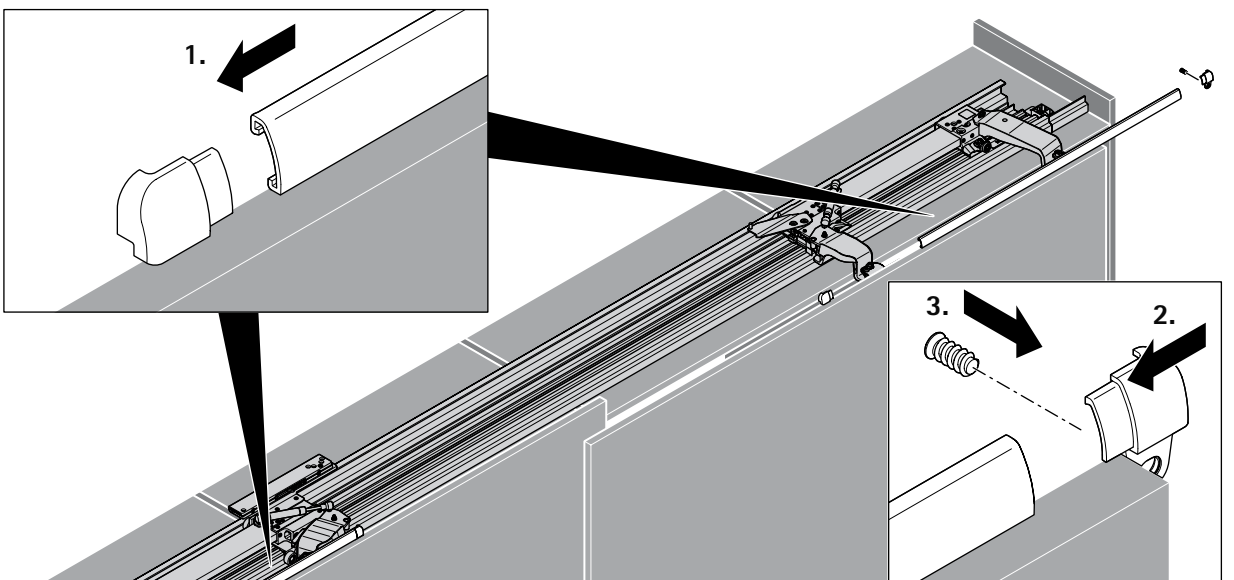
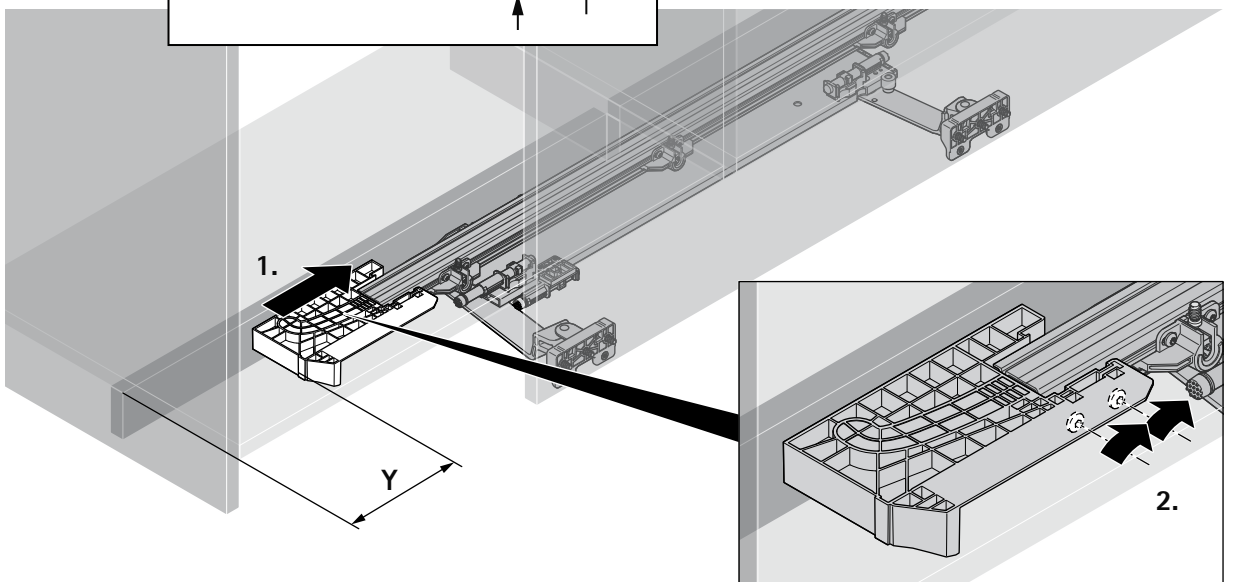
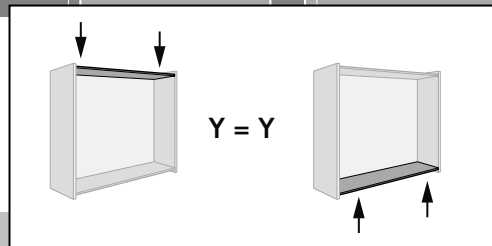
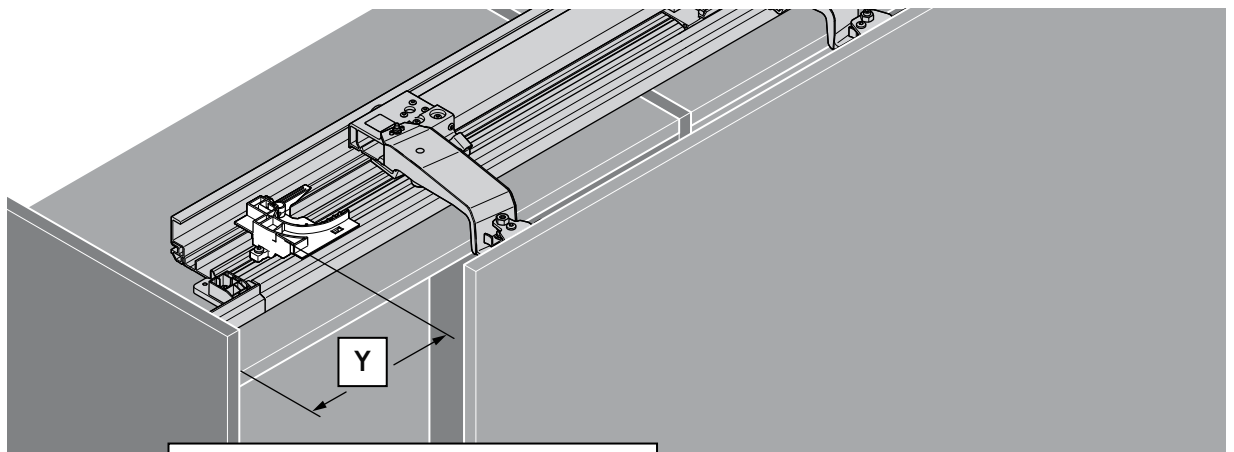

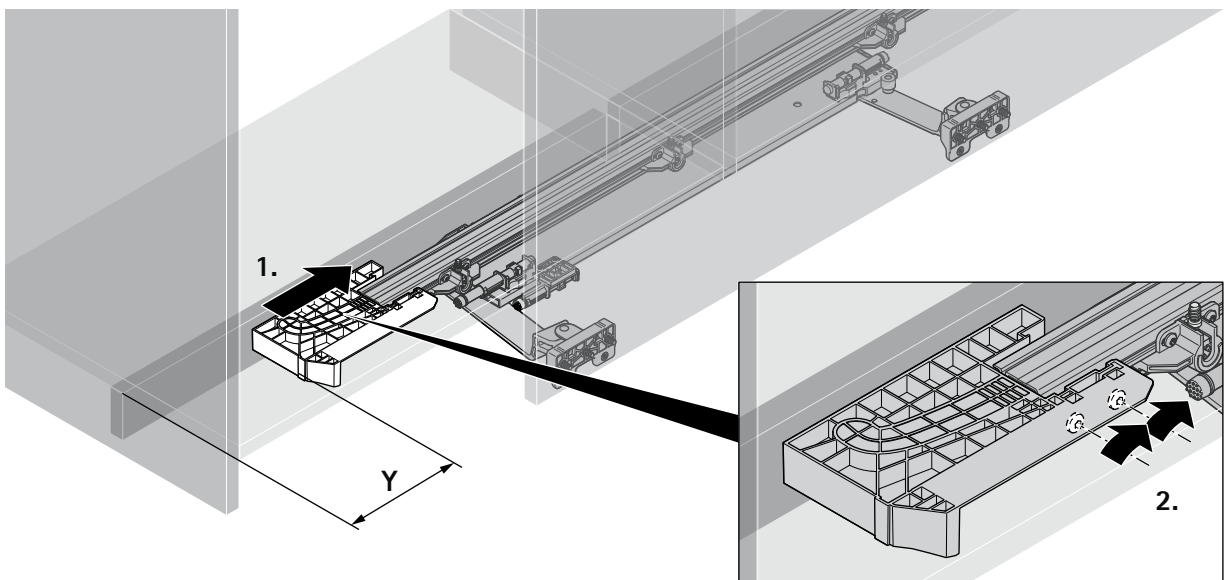
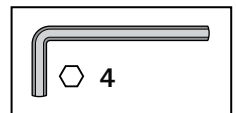
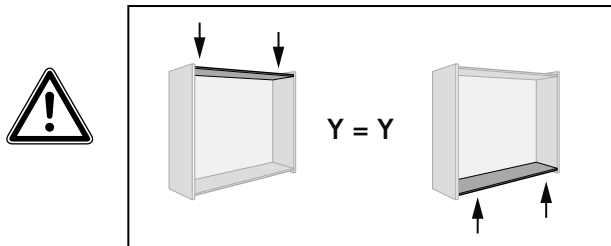
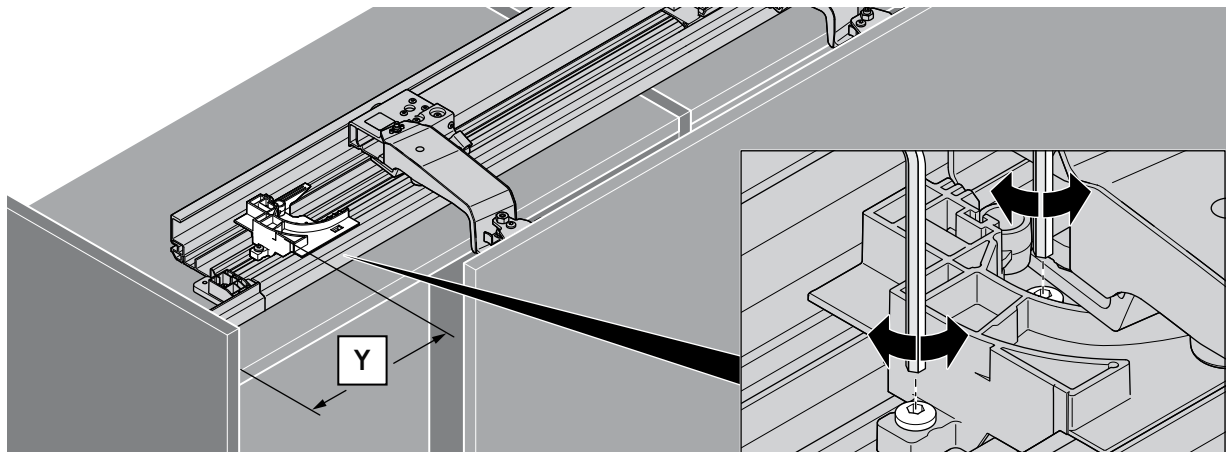
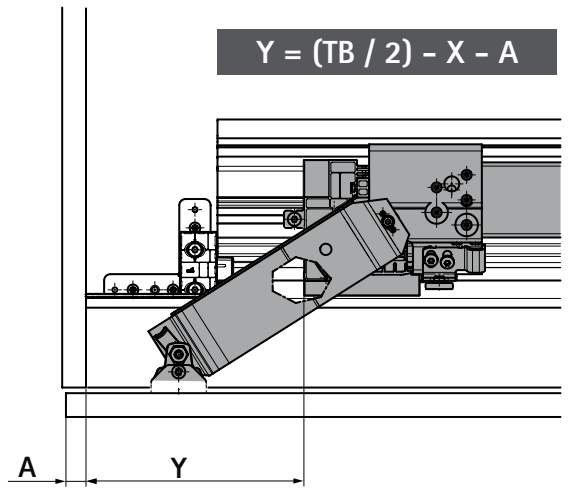
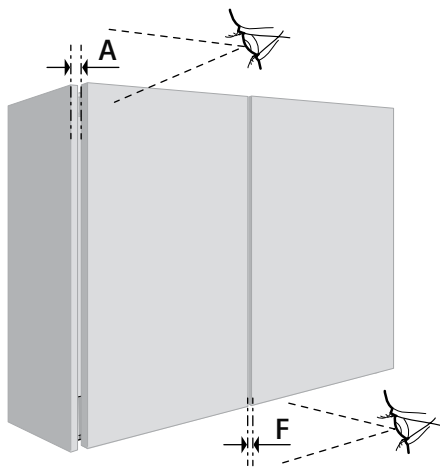

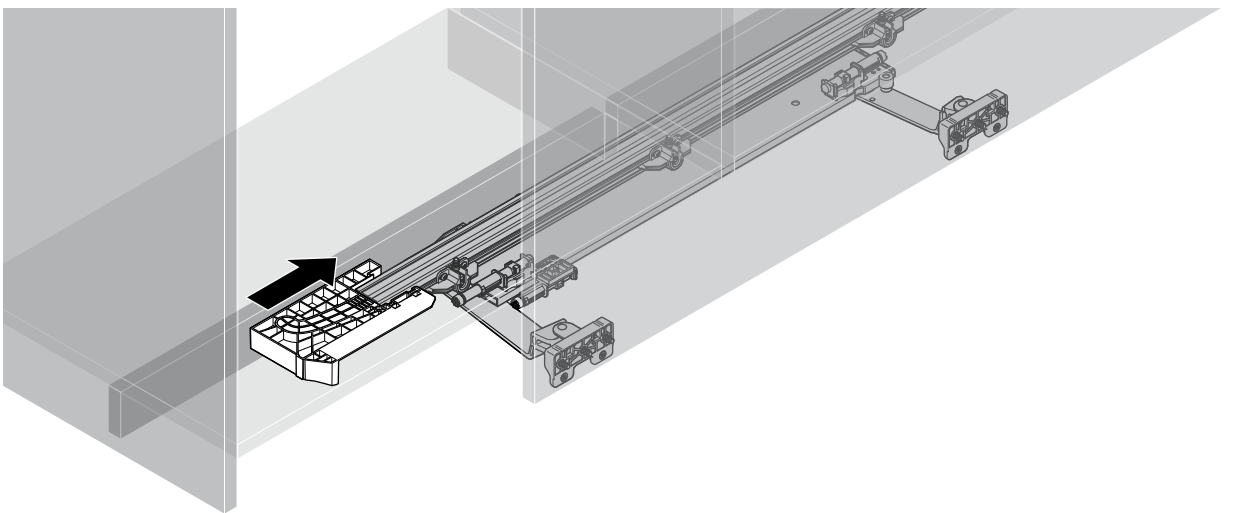
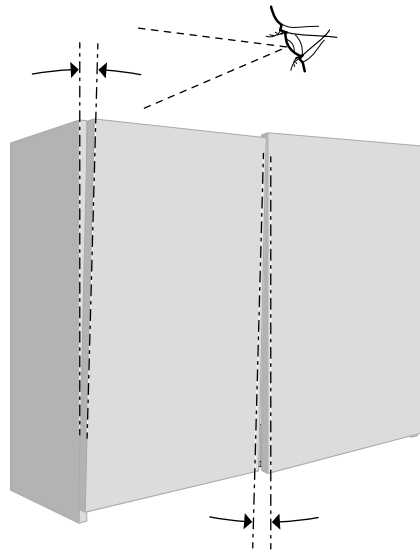
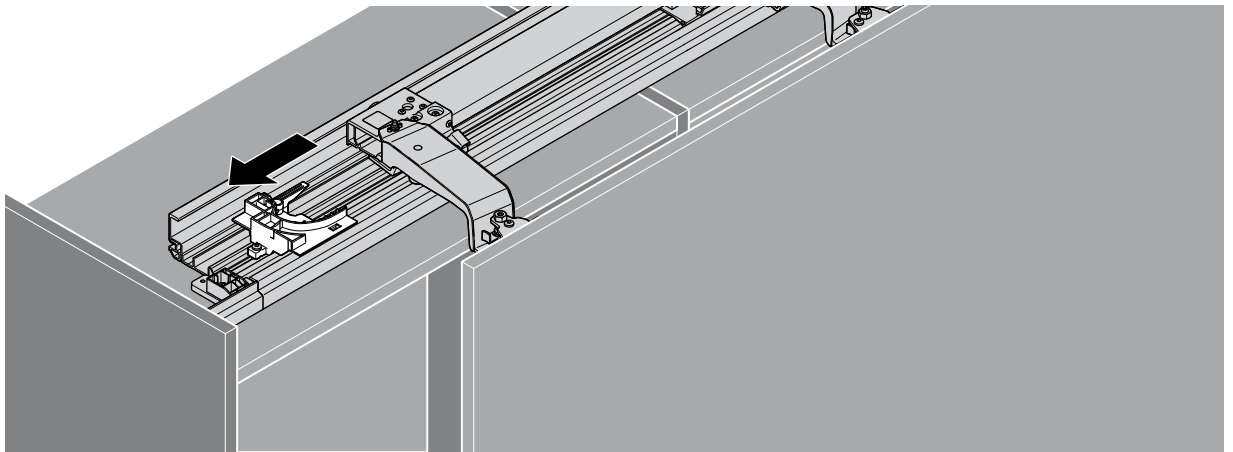

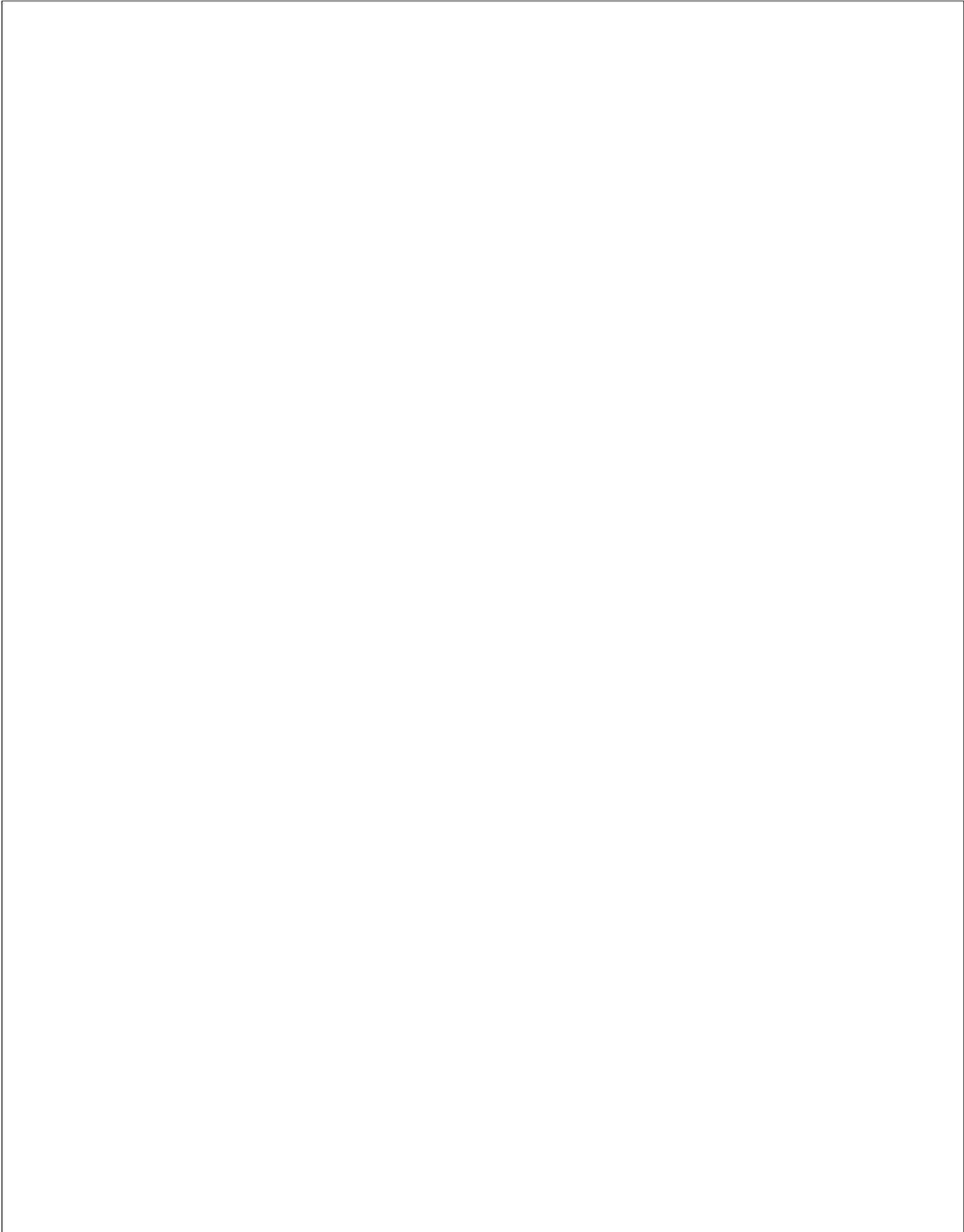

© Hettich Marketing- und Vertriebs GmbH & Co. KG

Der Nachdruck dieser Montageanleitung, auch auszugsweise, ist nur mit schriftlicher Einwilligung der Hettich Marketing- und Vertriebs GmbH & Co. KG zugelassen.

Sämtliche in dieser Montageanleitung genannten Bezeichnungen von Erzeugnissen sind Marken-/Warenzeichen der jeweiligen Firmen.