

<http://www.hettich.com/short/15a1d3>

i

4 x
3,5 x 25 mm

10 x
3,5 x 12 mm

8 x / 10 x
4 x 16 mm

1 x
3,5 x 30 mm

2 x
3,5 x 20 mm

1x

1x

1x

i

	Stahlrückwand/ Steel rear panel	Holzrückwand/ Wooden rear panel	Aluminiumrückwand/ Aluminium rear panel
A	NL - 3	NL + 10	NL - 3
B	LB - 2 x EB - 51,5	LB - 2 x EB - 51,5	LB - 2 x EB - 51,5
C	-	LB - 2 x EB - 63	LB - 2 x EB - 63
D	-	65,5	-

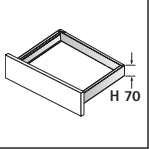

i

Quadro 25

Quadro V6

Quadro V6+

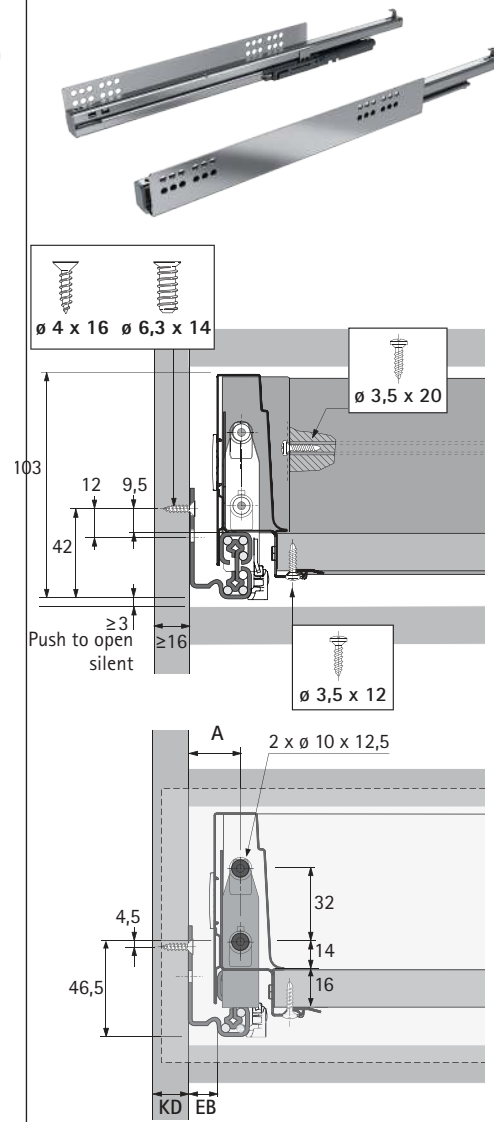
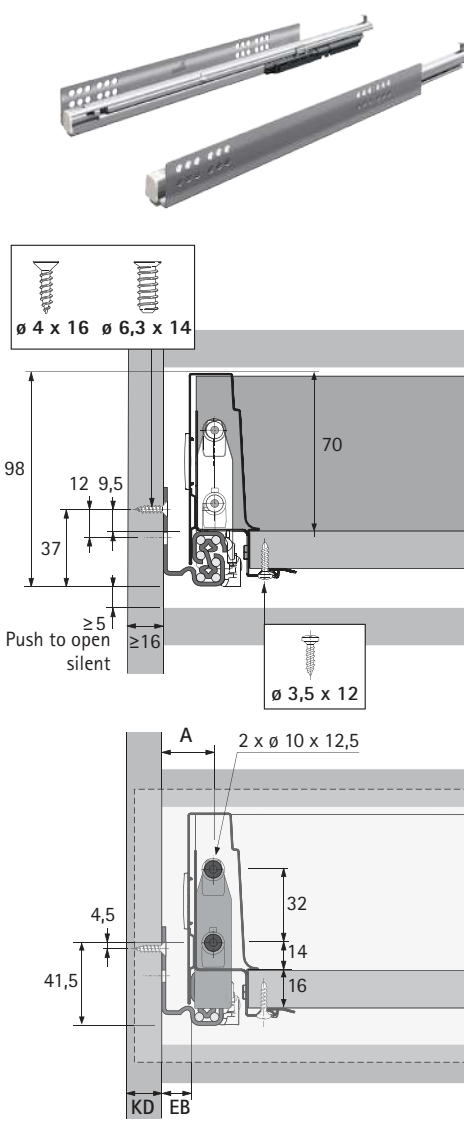
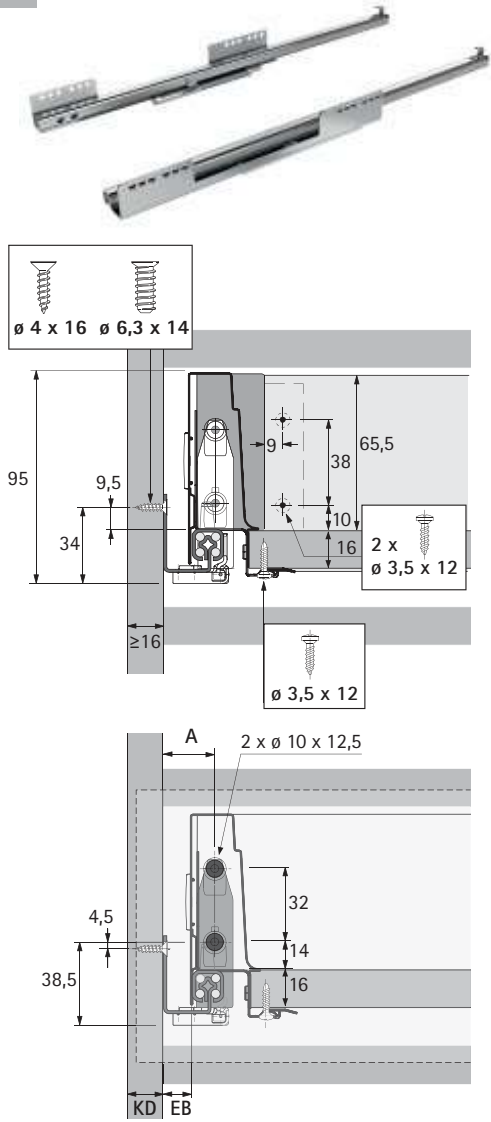

KD mm	16	18	19
EB mm	12,5	10,5	9,5
A mm	23	21	20

1

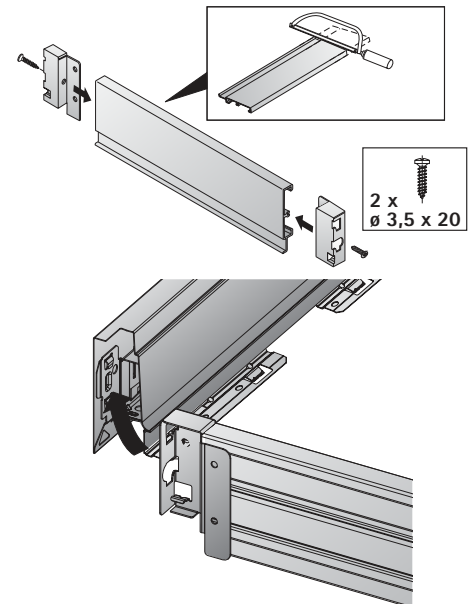
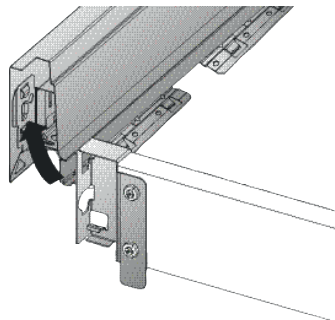
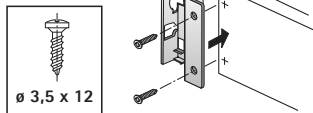
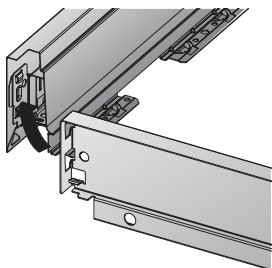

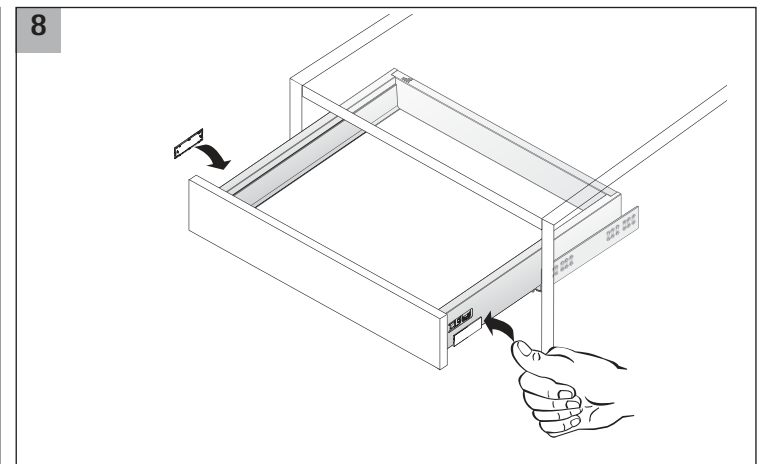
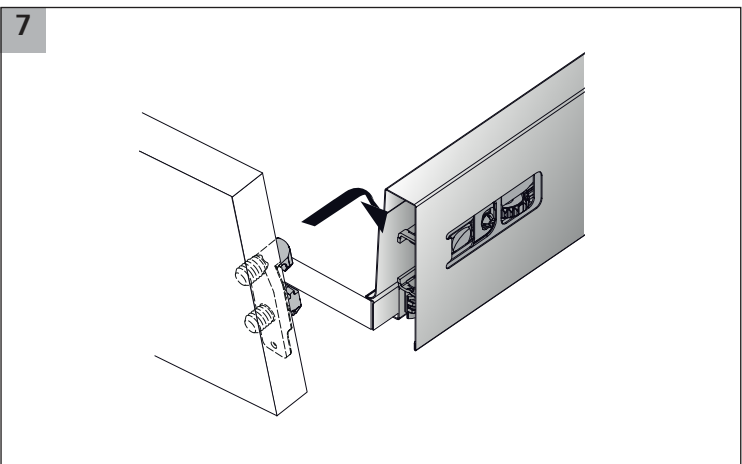
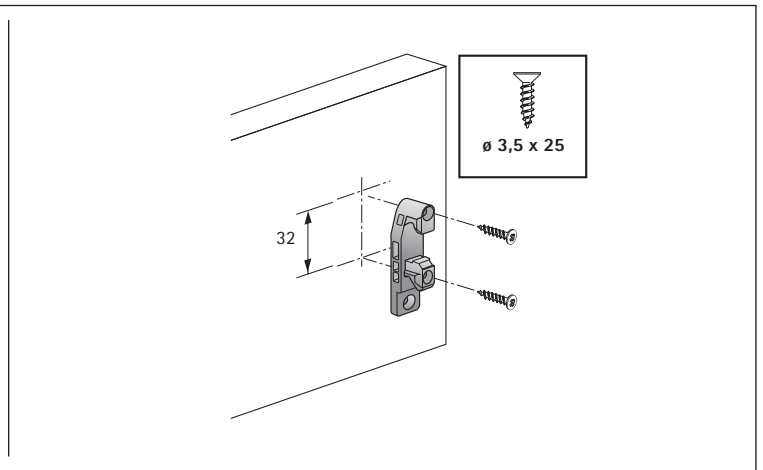
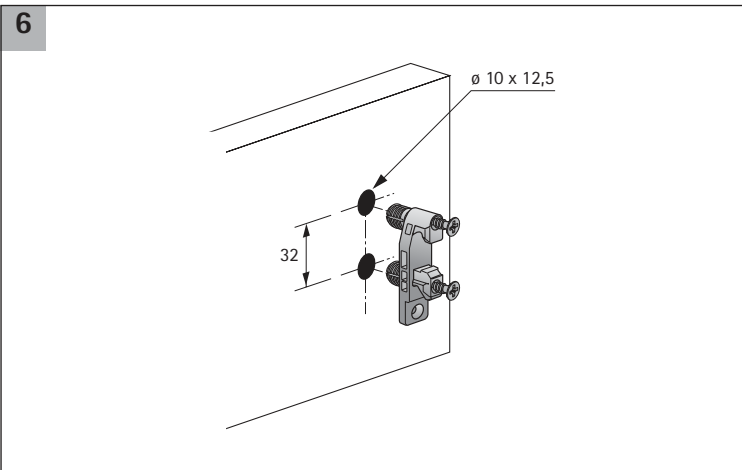
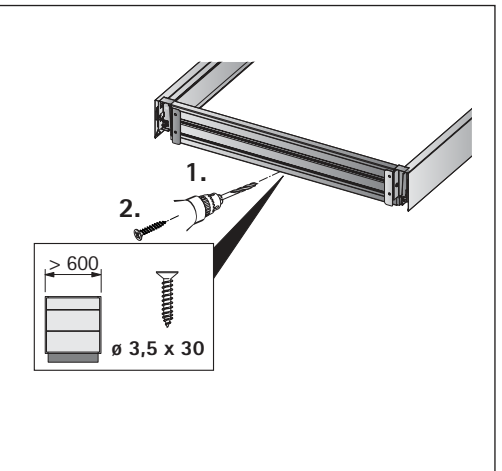
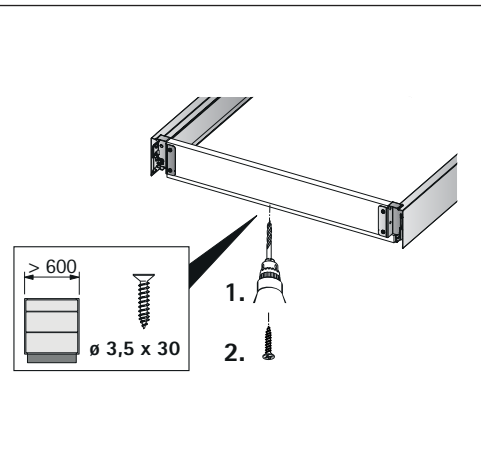
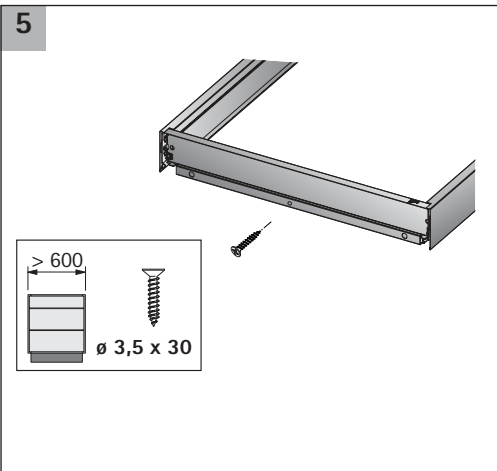
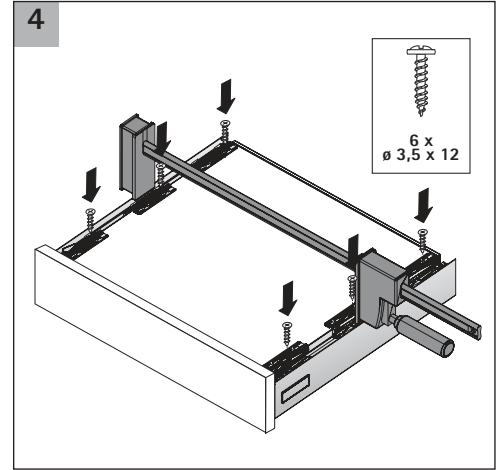
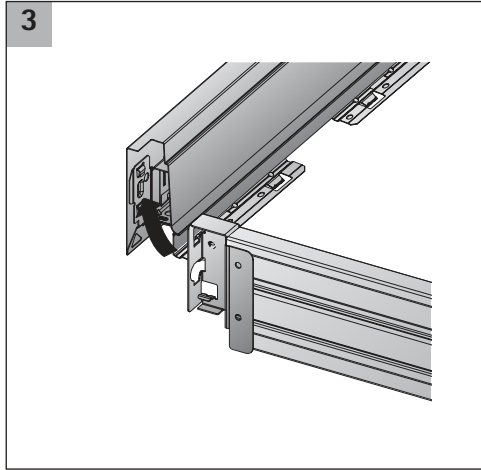
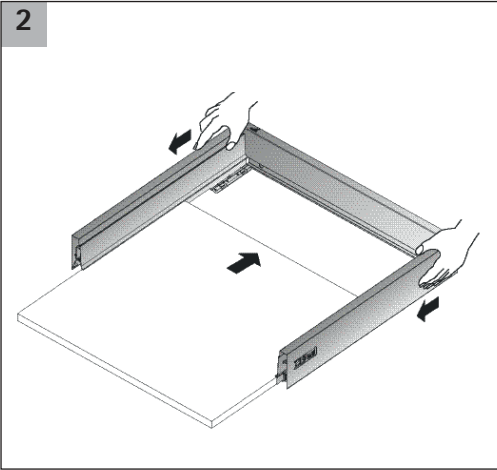
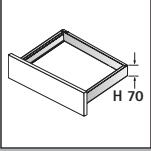

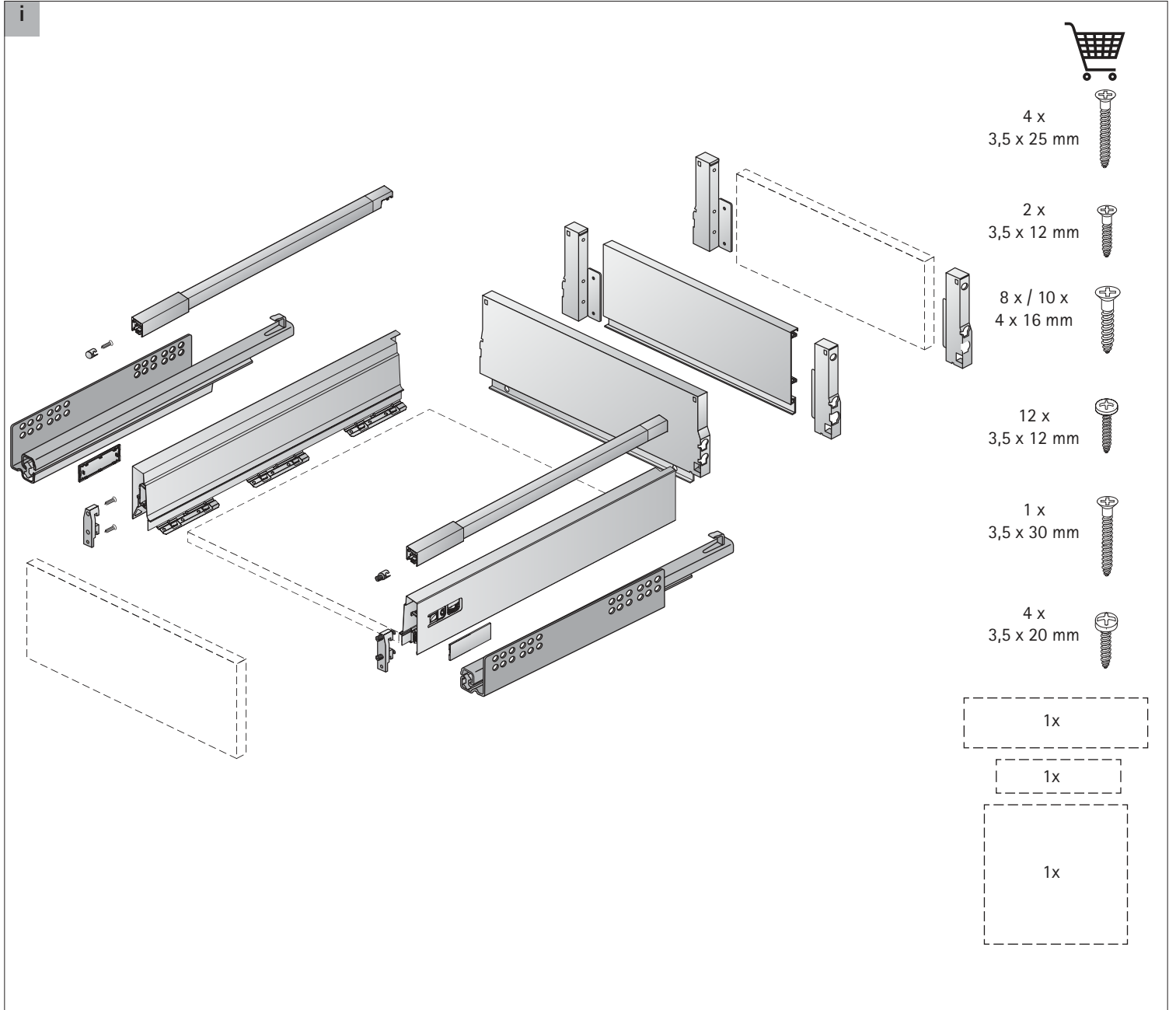
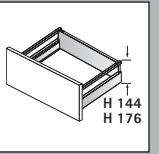

i

	Stahlrückwand/ Steel rear panel	Holzhückwand/ Wooden rear panel	Aluminiumrückwand/ Aluminium rear panel
A	NL - 3	NL + 10	NL - 3
B	LB - 2 x EB - 51,5	LB - 2 x EB - 51,5	LB - 2 x EB - 51,5
C	-	LB - 2 x EB - 63	LB - 2 x EB - 63
D	-	144	-

	Stahlrückwand/ Steel rear panel	Holzhückwand/ Wooden rear panel
A	NL - 3	NL + 10
B	LB - 2 x EB - 51,5	LB - 2 x EB - 51,5
C	-	LB - 2 x EB - 63
D	-	176

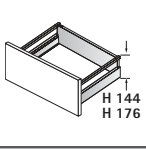

i

Quadro 25

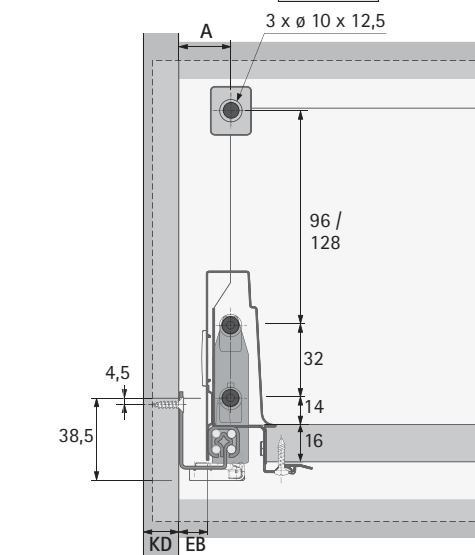
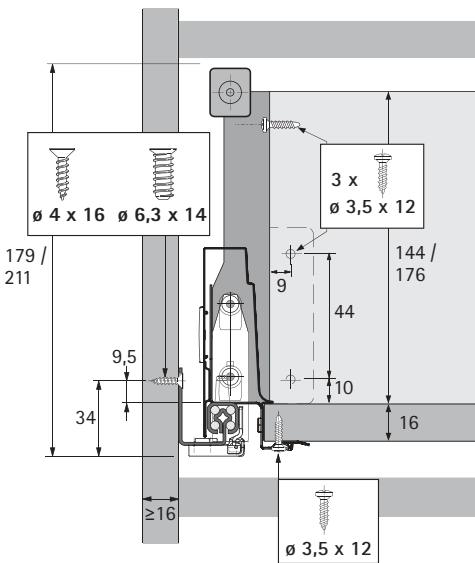

Quadro V6

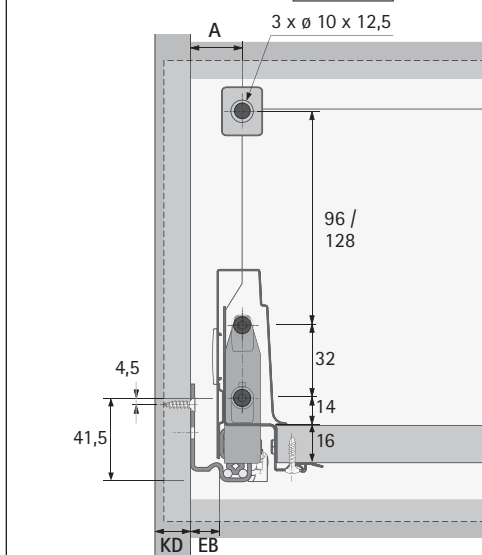
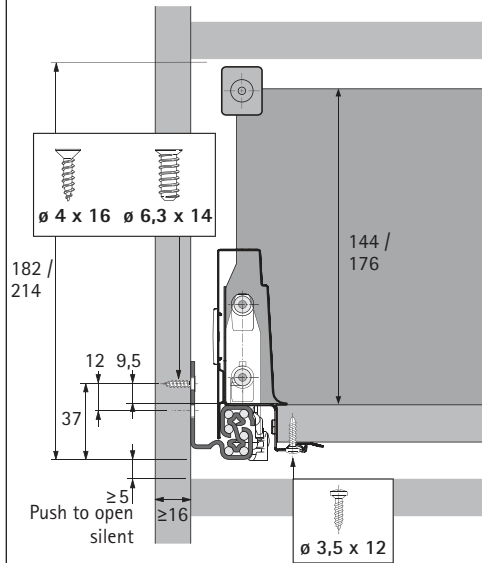

Quadro V6+

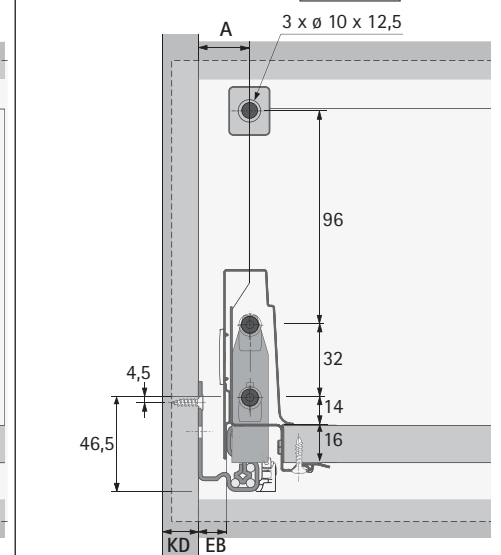
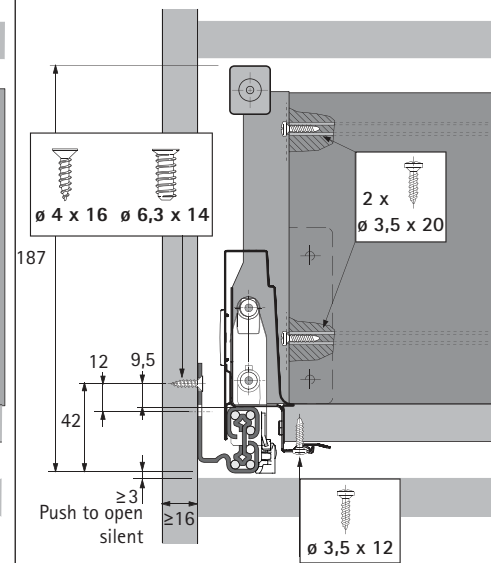

KD mm	16	18	19
EB mm	12,5	10,5	9,5
A mm	23	21	20

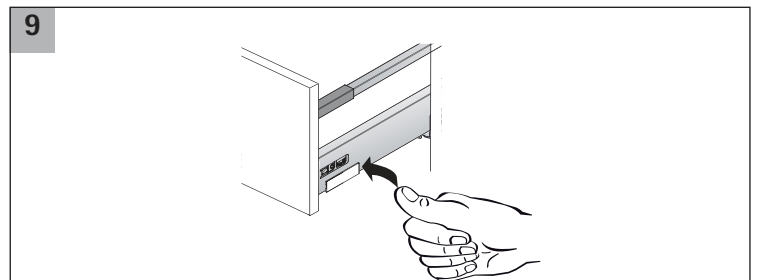
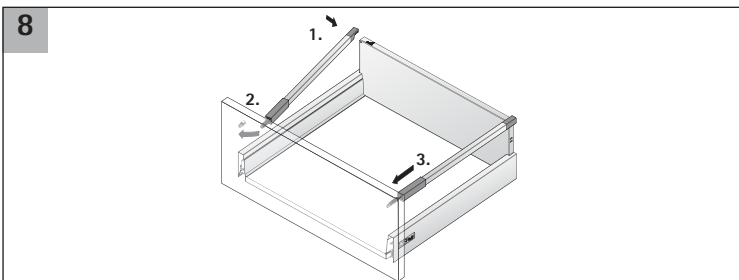
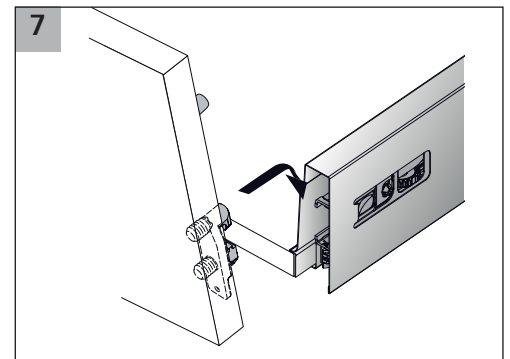
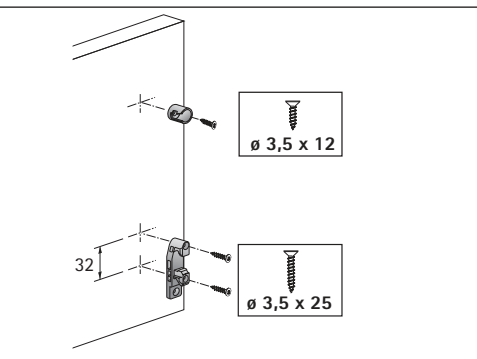
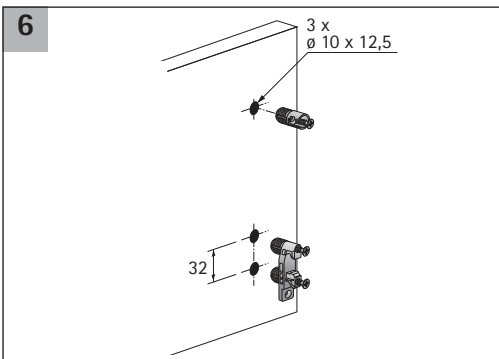
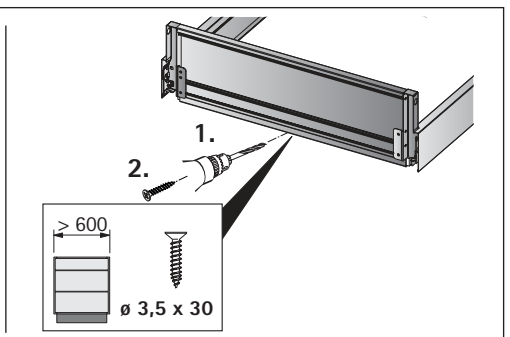
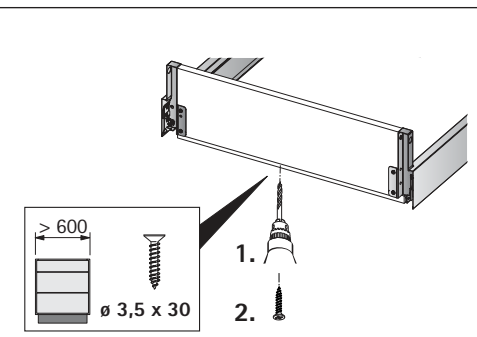
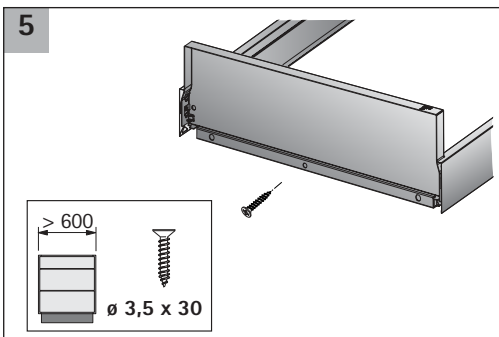
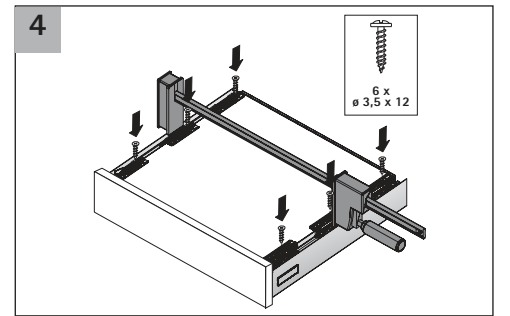
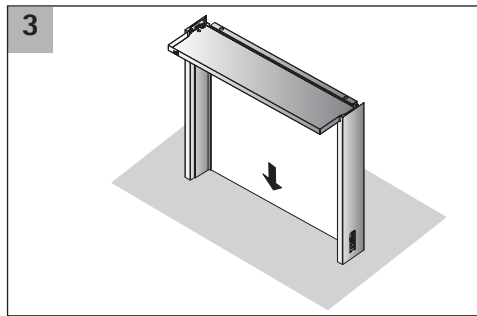
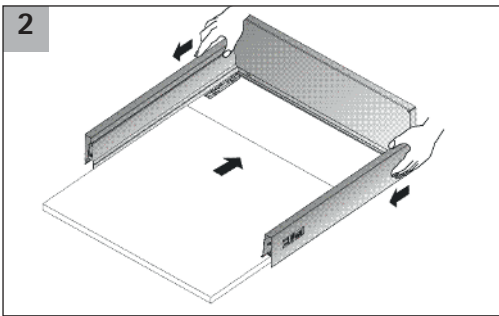
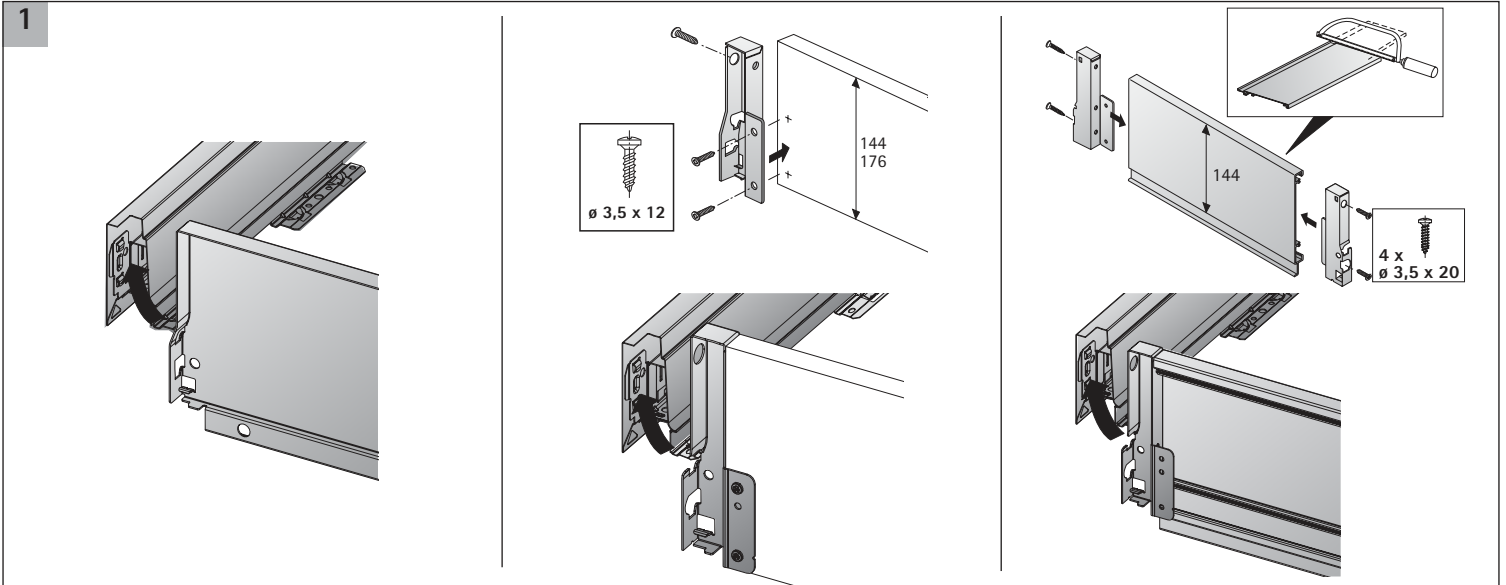
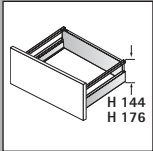

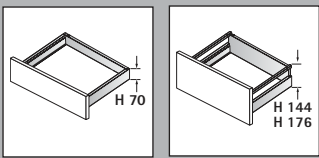

i Quadro 25

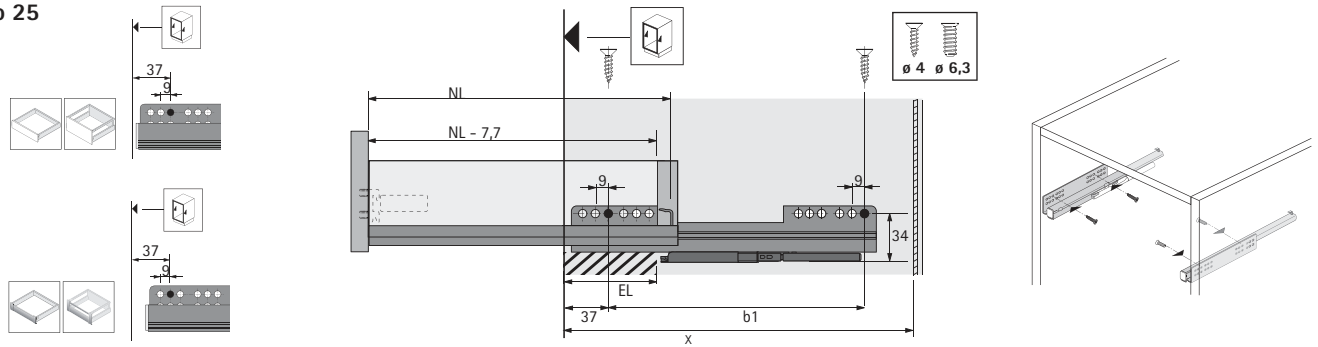

NL mm	b1 mm	EL mm	X mm	X mm
260	160	50	279	288
300	160	70	315	324
350	160	70	365	374
420	256	82	435	444
470	256	94	485	494
520	256	106	535	544

Quadro V6

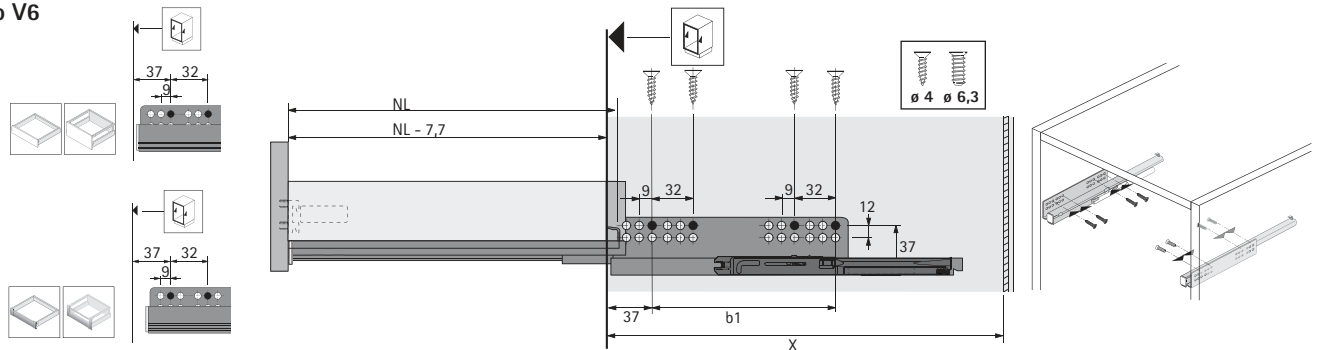

NL mm	b1 mm	X mm	X mm
260	160	279	288
300	160	315	324
350	160	365	374
420	224	435	444
470	256	485	494
520	256	535	544

Quadro V6+

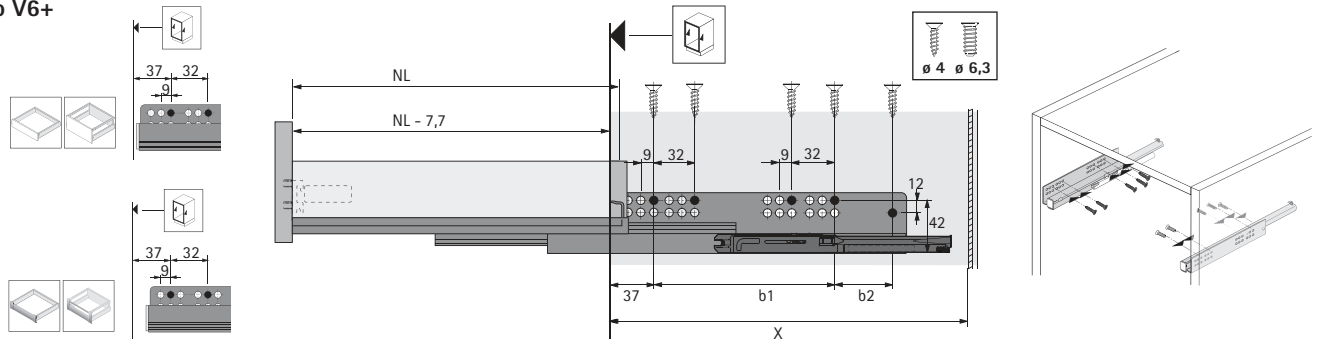

NL mm	b1 mm	b2 mm	X mm	X mm
300	160	-	315	324
350	192	-	365	374
420	224	-	435	444
470	256	-	485	494
520	256	-	535	544
620	352	64	635	644

